

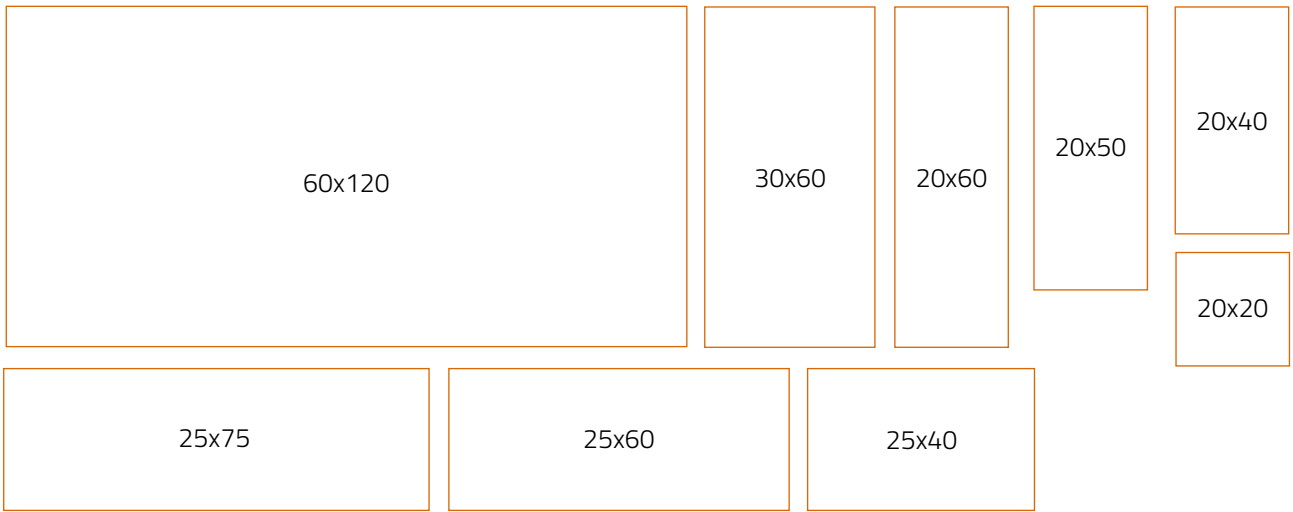

**DRESS
YOUR
HOME**

FORMATI | SIZES

RIVESTIMENTI | WALL TILES



PAVIMENTI | FLOOR



LEGNI | WOOD

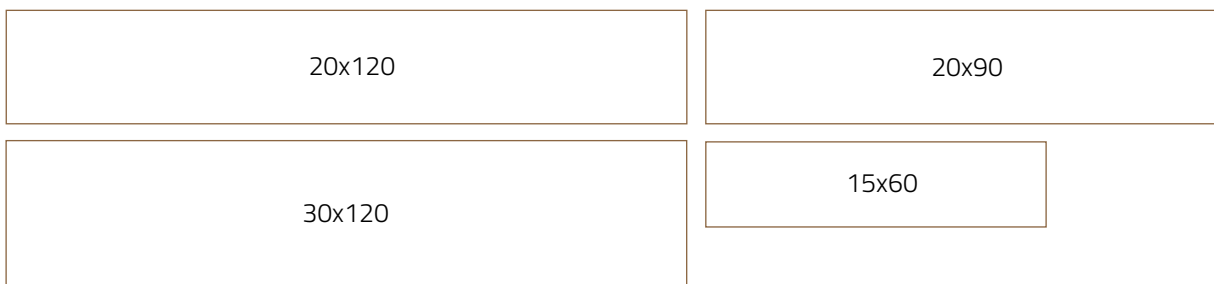

INDICE | INDEX

INDICE ALFABETICO | ALPHABETICAL INDEX

RIVESTIMENTI | WALL TILES

PAG.		Formato
304	ANTARES	20x50
102	BEST	25x60
300	BRAVA	25x60
184	DECORI RESINA	60x120
170	DECORI URBAN STONE	60x120
46	ESSENZIALE	25x75
10	FEELWOOD	25x75
60	FIJI	25x75
306	FLORA	20x50
30	KARMA	25x75
82	KI MATCH	25x60
116	LUCE LUX	20x20
116	LUCE MATT	20x20
108	MARVEL	20x60
52	NAIF	25x75
40	NATIVE	25x75
20	PAPEETE	25x75
72	PORTOFINO	25x60
66	SETA	30x60
112	SHINE	20x60
92	VERNISSAGE	25x60
305	VICKY	20x50
299	WEISS	25x60
299	WHITE AND WHITE	25x40
302	WHITE AND WOOD	25x40
66	WHITE PROJECT	30x60
299	WHITE SPRING	20x40

PAVIMENTI | FLOOR TILES

PAG.		Formato
314	ALPI	60x60
152	BAITA	20x90
312	BALI	60x60 30x60
236	BLOCK	90x90 60x60
198	CITY LIFE	60x120 60x60 30x60
284	COTTI D'EREMO	22x44
214	DEA	60x120 90x90 40x60 22x22 60x60 2cm
274	ETERNA	30x60 22x44
206	LIMESTONE	60x120 90x90 60x60
248	LUBERON	40x60
242	LUCANIA	60x60
264	METROPOLIS	30x60 22x44
224	MISTERY	60x120 60x60 30x60
310	NOTTINGHAM	15x60
184	RESINA	60x120 90x90 60x60
314	RIFLESSI	45x45
136	OAK	30x120 20x120 20x90
144	ONTARIO	30x120 20x120
308	OUT & IN	15x60
292	PALINURO	34x34
280	PIETRA DI BISMANTOVA	30x60
272	POLAR	22x44
252	POLINESIA	30x60 22x22 60x60 2cm
124	TENDER	20x120
160	URBAN STONE	60x120 80x80 60x60 30x60 60x60 2cm

WALL & FLOOR | **COMMODITY** | PAG 298

TECH INFO | **INFORMAZIONI GENERALI** | PAG 322

◆◆ | GLOSSY | LUCIDO

◆ | WHITE BODY | PASTA BIANCA

INDICE PER FORMATO RIVESTIMENTO | INDEX BY SIZE WALL TILE

60x120

DECORI URBAN STONE 170

DECORI RESINA 184

30x60

WHITE PROJECT ◆ 66

SETA 66

25x40

WHITE AND WHITE 299

WHITE AND WOOD 302

20x60

MARVEL 108

SHINE ◆◆ 112

20x50

ANTARES 304

FLORA 306

VICKY ◆◆ 305

25x75

FEELWOOD 10

PAPEETE 20

ESSENZIALE 46

NATIVE 40

FIJI ◆◆ ◆ 60

KARMA 30

NAIF ◆ 52

25x60

PORTOFINO 72

BEST 102

KI MATCH 82

VERNISSAGE 92

WEISS ◆◆ 299

BRAVA ◆◆ 300

20x40

WHITE SPRING ◆◆ 299

20x20

LUCE LUX ◆◆ 116

LUCE MATT 116

Special 2 CM | 2 centimetri | PAG 316



60x120

RESINA	184
LIMESTONE	206
URBAN STONE	160
MISTERY	224
CITY LIFE	198
DEA	214
DECORI RESINA	184
DECORI URBAN STONE	170

90x90

RESINA	184
BLOCK	236
DEA	214
LIMESTONE	206

80x80

URBAN STONE	160
-------------	-----

60x60 2cm

URBAN STONE	160
DEA	214
POLINESIA	252

60x60

RESINA	184
LIMESTONE	206
URBAN STONE	160
MISTERY	224
CITY LIFE	198
BLOCK	236
ALPI	314
LUCANIA	242
BALI	312

40x60

DEA	214
LUBERON	248

45,5x45,5

RIFLESSI	314
----------	-----

34x34

PALINURO	292
----------	-----

30x60

URBAN STONE	160
MISTERY	224
CITY LIFE	198
ETERNA	274
PIETRA DI BISMANTOVA	280
METROPOLIS	264
POLINESIA	252
BALI	312

22x22

DEA	214
POLINESIA	252

21,6x43,5

POLAR	272
ETERNA	274
METROPOLIS	264
COTTI D'EREMO	284

LEGNO | WOOD | PAG 122

30x120

ONTARIO	144
OAK	136

20x120

ONTARIO	144
OAK	136
TENDER	124

20x90

OAK	136
BAITA	152

15x60

OUT & IN	308
NOTTINGHAM	310





RIVESTIMENTI | WALL TILES

Web site
More info

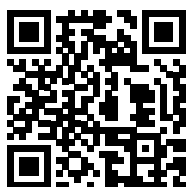

FEELWOOD

Bicottura tradizionale
Traditional double fired
Bi-cuisson traditionnelle
Zweibrandfliesen

Monocalibro / Monocaliber / Monocalibre / In einem werkmass



25x75
10"x29,5"



FORMATO Size	SPESSORE Thickness	SCATOLE Boxes			PALETTE Pallets		
		pcs	m ²	kg	box	m ²	kg
FEELWOOD 25x75	8	8	1,50	20,50	45	67,50	940,50
HEMP 25x75	8	8	1,50	20,50	45	67,50	940,50
CANNÈ	8	8	1,50	20,50	45	67,50	940,50
FEEL MARBLE 25x75	8	8	1,50	20,50	45	67,50	940,50
FEEL MIX 25x75	8	8	1,50	20,50	45	67,50	940,50
COMPO FEEL HEMP 25x75	8	6	1,125	15,37	60	67,50	940,50



FeelWood



COMPO FEEL HEMP





WALL TILE | **CANNÉ ALMOND + FEEL MARBLE GREY** | 25x75



WALL TILE | **FEEL MARBLE ALMOND + CANNÉ BROWN** | 25x75



WALL TILE | **HEMP ALMOND + COMPO FEEL HEMP** | 25x75



WALL TILE | **FEEL MIX GREY + FEEL MIX IVORY** | 25x75

FEELWOOD | 25x75

▼
8 mm
▲

HEMP



IFWR06 - HEMP ALMOND / 25x75

■ 71



IFWR05 - HEMP GREY / 25x75

■ 71



IFWR07 - HEMP BROWN / 25x75

■ 71

CANNÈ



IFWR11 - CANNÈ ALMOND / 25x75

■ 71



IFWR10 - CANNÈ GREY / 25x75

■ 71



IFWR09 - CANNÈ BROWN / 25x75

■ 71

Feel MIX



IFWD03 - FEEL MIX ALMOND / 25x75

■ 66



IFWD02 - FEEL MIX GREY / 25x75

■ 66



IFWD04 - FEEL MIX IVORY / 25x75

■ 66

Feel MARBLE



IFWR12 - FEEL MARBLE ALMOND / 25x75

■ 66



IFWR13 - FEEL MARBLE GREY / 25x75

■ 66



IFWR01 - FEEL WOOD IVORY / 25x75

■ 66



IFWR01 25x75
FEELWOOD IVORY



IFWR08 - DEC. COMPO FEEL HEMP [A+B+C] / 25x75

115



Cod.

Compo Feel HEMP

*NB: prezzo per scatola completa.
*NB: price per full box.

90°
180°

HEMP Brown



90°
180°

CANNÈ Brown



MATCHING FLOOR | Pag. 314

ALPI | 60X60 | Rettificato



PF00021814 - ALPI GRIGIO / 60x60

66



PF00021813 - ALPI BEIGE / 60x60

66

FEELWOOD **HEMP**

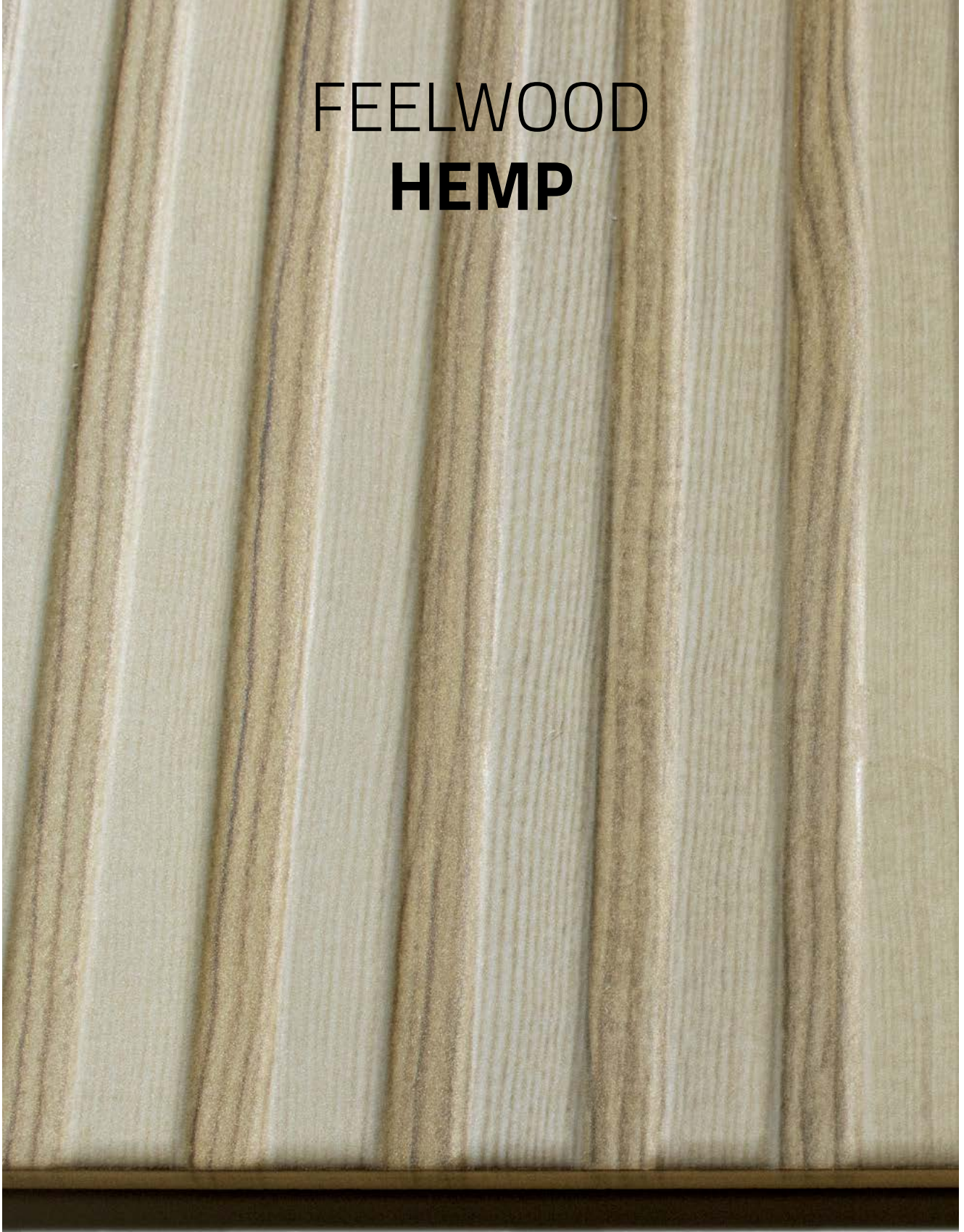

HEMP ALMOND

FEELWOOD CANNè

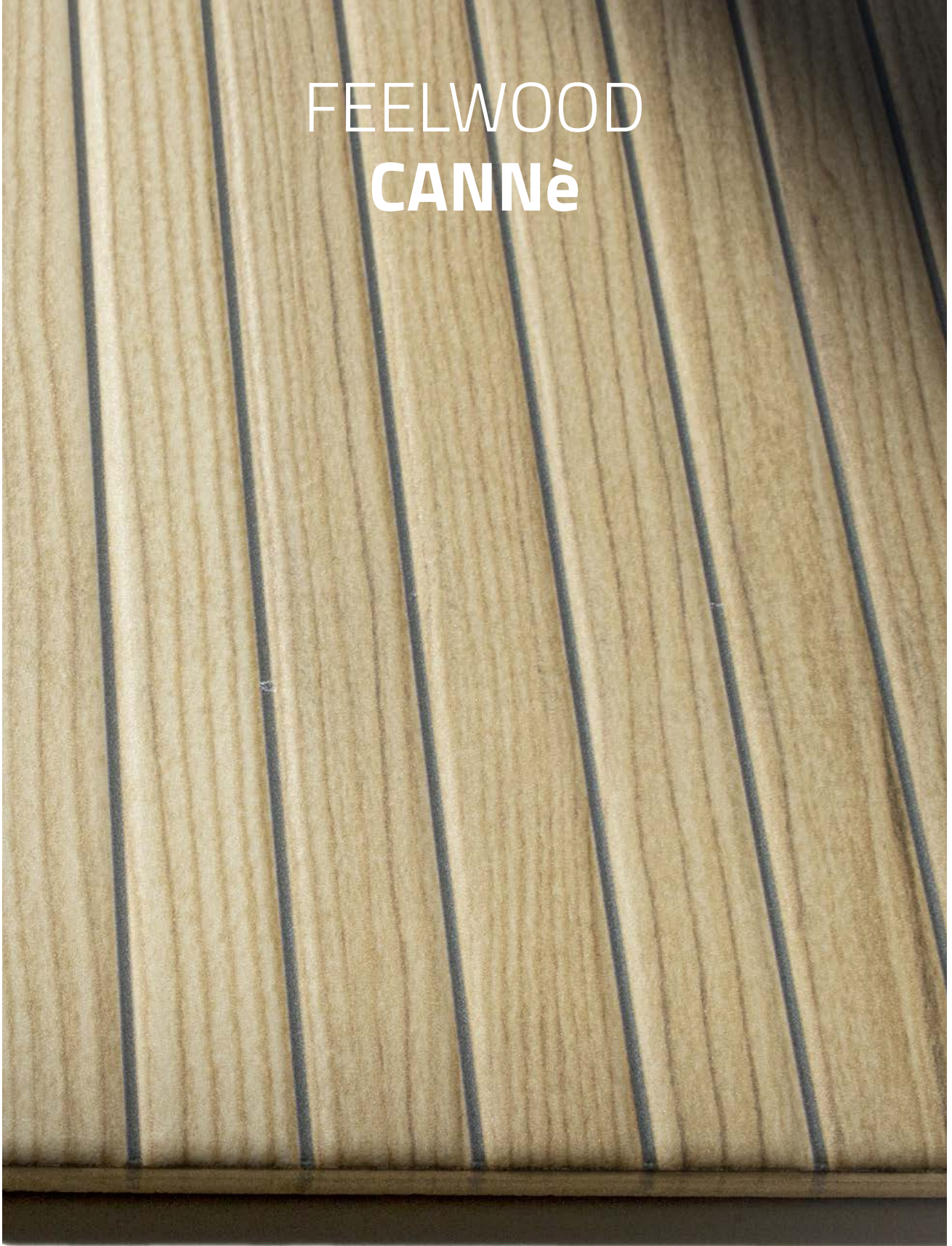

CANNè ALMOND

Web site
More info



PAPEETE

Bicottura tradizionale
Traditional double fired
Bi-cuisson traditionnelle
Zweibrandfliesen

Monocalibro / Monocaliber / Monocalibre / In einem werkmass

▼
8 mm
▲



25x75
10"x29,5"



FORMATO Size	SPESSORE Thickness	SCATOLE Boxes			PALETTE Pallets		
		pcs	m ²	kg	box	m ²	kg
FONDI 25x75	8	8	1,50	20,50	45	67,50	940,50
TAHITI 25x75	8	8	1,50	20,50	45	67,50	940,50
MOOREA 25x75	8	8	1,50	20,50	45	67,50	940,50



Papeete

TAHITI

PAPEETE

Papeete White



Cold



Warm

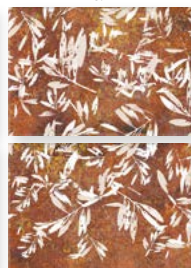

Papeete Cold



Papeete Warm

MOOREA

Essenziale Bianco

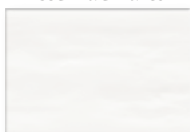

Cold

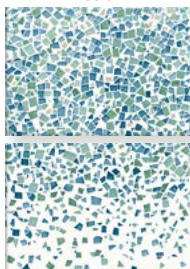

Warm





WALL TILE | PAPEETE **WHITE** + TAHITI **BLUE** + PAPEETE **COLD** | 25x75



WALL TILE | **TAHITI MAGENTA** | 25x75



WALL TILE | ESSENZIALE **BIANCO** + **MOOREA COLD** | 25x75



WALL TILE | ESSENZIALE **BIANCO + MOOREA WARM** | 25x75

PAPEETE | 25x75

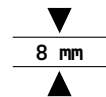

IPER01 - PAPEETE **WHITE** / 25x75 ■ 64



IPER01 - PAPEETE **WHITE** / 25x75 ■ 64



IPED01 - DEC. TAHITI **BLUE** / 25x75 ■ 71



IPED02 - DEC. TAHITI **MAGENTA** / 25x75 ■ 71



IPER02. - COMPO TAHITI **BLUE** [A+B] / 25x75 ■ 96



IPER03. - COMPO TAHITI **MAGENTA** [A+B] / 25x75 ■ 96



IPER06 - PAPEETE **COLD** / 25x75 ■ 64



IPER07- PAPEETE **WARM** / 25x75 ■ 64

Cod. *NB: prezzo per scatola completa.
*NB: price per full box.

PAPEETE | 25x75

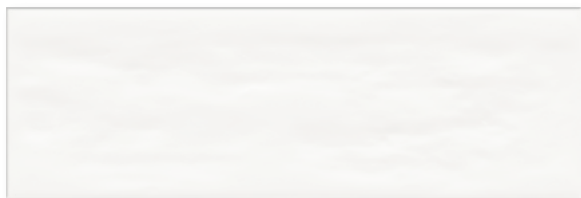

IESR01 - ESSENZIALE **BIANCO** / 25x75 ■ 64

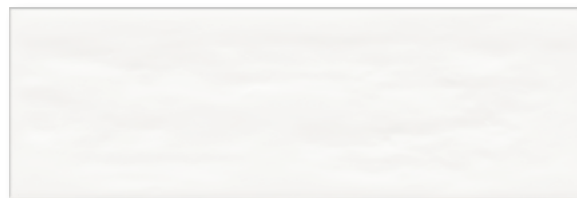

IESR01 - ESSENZIALE **BIANCO** / 25x75 ■ 64



IPED03 - DEC. MOOREA **COLD** / 25x75 ■ 71



IPED04 - DEC. MOOREA **WARM** / 25x75 ■ 71

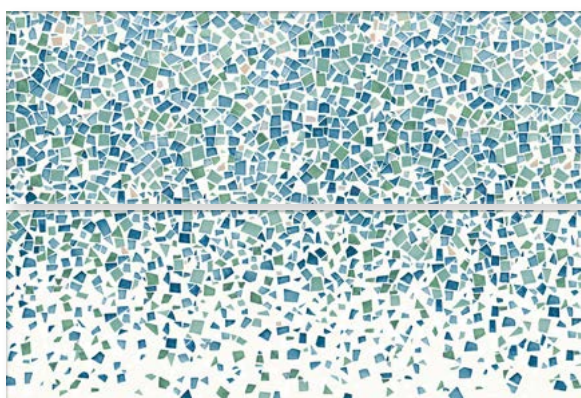

IPER04. - COMPO MOOREA **COLD** [A+B] / 25x75 ■ 96

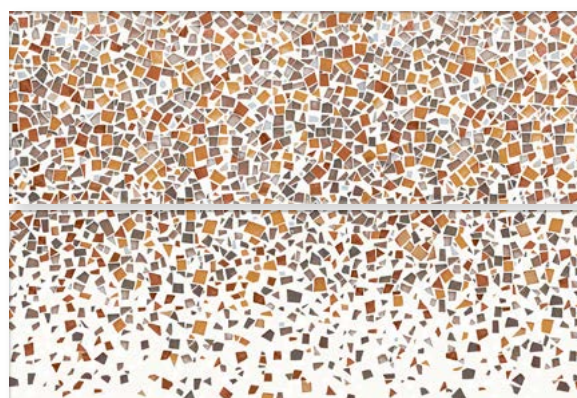

IPER05. - COMPO MOOREA **WARM** [A+B] / 25x75 ■ 96

Cod. *NB: prezzo per scatola completa.
*NB: price per full box.



PAPEETE WHITE

PAPEETE



TAHITI MAGENTA

Web site
More info



KARMA

Bicottura tradizionale
Traditional double fired
Bi-cuisson traditionnelle
Zweibrandfliesen

Monocalibro / Monocaliber / Monocalibre / In einem werkmass

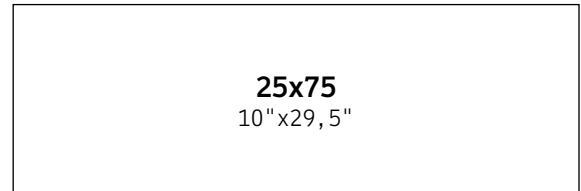

Size Formato	SCATOLE Boxes			PALETTE Pallets		
	Pz	m ²	Kg	Box	m ²	Kg
Cm 25x75						
25X75	8	1,50	20,50	45	67,50	940,50
STRIPE 25X75	8	1,50	20,50	45	67,50	940,50
MOKSA + LEVIOSA + ORIGAMI	8	1,50	20,50	45	67,50	940,50



Karma

KARMA

Ivory

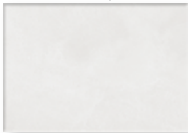

STRIPE

Ivory



MOKSA

Cold



ORIGAMI



COMP. EDEN



COMP. NATURA



COMP. RELAX



Taupe



Taupe



Warm



LEVIOSA



Blu



Blu



Smeraldo



Smeraldo





WALL TILE | KARMA IVORY + COMPO NATURA | 25x75



WALL TILE | **COMPO RELAX + KARMA TAUPE** | 25x75



WALL TILE | **MOKSA WARM** | 25x75



WALL TILE | **KARMA SMERALDO + COMPO EDEN** | 25x75



WALL TILE | **STRIPE SMERALDO** | 25x75



WALL TILE | DEC ORIGAMI + TAUPE | 25x75

KARMA | 25x75

▼
8mm
▲

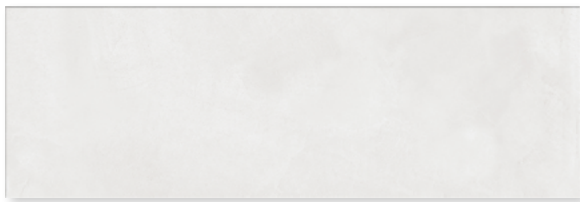

IKAR01 - KARMA **IVORY** / 25x75 ■ 64



IKAR05 - STRIPE K. **IVORY** / 25x75 ■ 66



IKAR02 - KARMA **TAUPE** / 25x75 ■ 64



IKAR06 - STRIPE K. **TAUPE** / 25x75 ■ 66



IKAR03 - KARMA **BLU** / 25x75 ■ 64



IKAR07 - STRIPE K. **BLU** / 25x75 ■ 66



IKAR04 - KARMA **SMERALDO** / 25x75 ■ 64



IKAR08 - STRIPE K. **SMERALDO** / 25x75 ■ 66

MOKSA



IKAR14 - DEC **MOKSA COLD** / 25x75 ■ 77

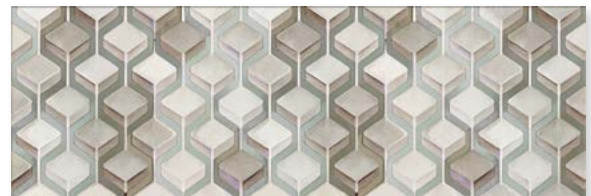

IKAR15 - DEC **MOKSA WARM** / 25x75 ■ 77

MOKSA

LEVIOSA



IKAR13 - DEC K. **LEVIOSA** / 25x75 ■ 77

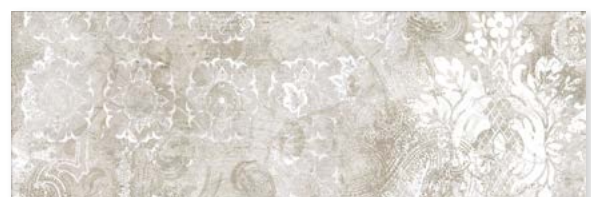

IKAR11 - DEC K. **ORIGAMI** / 25x75 ■ 71

ORIGAMI

KARMA

EDEN



IKAR12. - DEC K. COMPO EDEN [A+B+C] 25x75 ■ 118

*Nota: prezzo per scatola da 6 pz. 

NATURA



IKAR10. - DEC K. COMPO NATURA [A+B+C] 25x75 ■ 118

*Nota: prezzo per scatola da 6 pz. 

*NB: prezzo per scatola completa.
*NB: price per full box.

Cod.



**VIRTUAL
SHOWROOM**



www.ideaceramica.net/karma

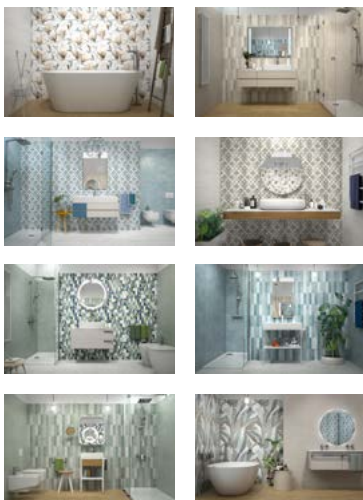

RELAX



IKAR09. - DEC K. COMPO RELAX [A+B+C+D] 25x75 ■ 126

*Nota: prezzo per scatola da 8 pz. 

*NB: prezzo per scatola completa.
*NB: price per full box.

Cod.

Web site
More info



NATIVE

Bicottura tradizionale
Traditional double fired
Bi-cuisson traditionnelle
Zweibrandfliesen

Monocalibro / Monocaliber / Monocalibre / In einem werkmass



25x75
10"x29,5"

Size
Formato

SCATOLE
Boxes



PALETTE
Pallets



Cm	25x75	Pz	m²	Kg	Box	m²	Kg
	25X75	8	1,50	20,50	45	67,50	940,50
	BLOCKS	8	1,50	20,50	45	67,50	940,50
	WALLBRICK	8	1,50	20,50	45	67,50	940,50
	OASI [A+B]	8	1,50	20,50	-	-	-
	MOSAICO 30x30	5	-	6	-	-	-
	Stick BLITZ 1x75	8	-	0,70	-	-	-





Native

NATIVE

Beige

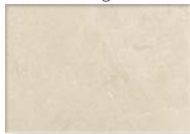

BLOCKS

Beige



WALLBRICK

Beige



COMP. OASI



Grigio



Grigio



Grigio



Ghiaccio

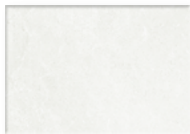



WALL TILE | **WALLBRICK GRIGIO + NATIVE GHIACCIO** | 25x75



WALL TILE | **BLOCKS GRIGIO + NATIVE GHIACCIO** | 25x75

NATIVE | 25x75

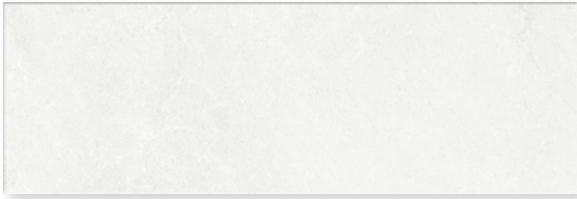
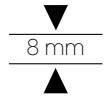

INVR01 - NATIVE - GHIACCIO / 25x75 ■ 66

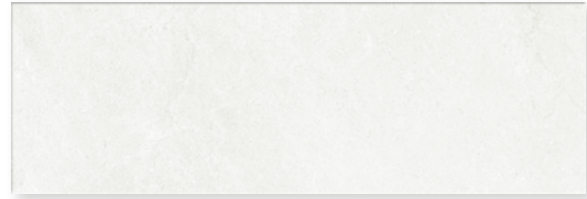

INVR01 - NATIVE - GHIACCIO / 25x75 ■ 66



INVR06 - BLOCKS - BEIGE / 25x75 ■ 71



INVR07 - BLOCKS - GRIGIO / 25x75 ■ 71



INVR04 - WALLBRICK - BEIGE / 25x75 ■ 71



INVR05 - WALLBRICK - GRIGIO / 25x75 ■ 71

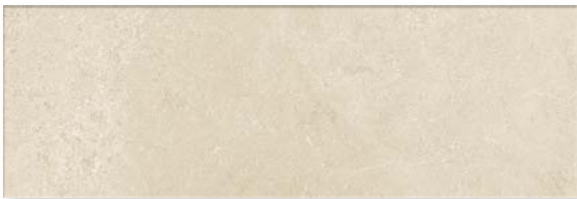

INVR02 - NATIVE - BEIGE / 25x75 ■ 66



INVR03 - NATIVE - GRIGIO / 25x75 ■ 66



UR014 Stick BLITZ BRONZO / 1x74,8 ■ 28



UR015 Stick BLITZ SILVER / 1x74,8 ■ 28



INVM08 - COMP - OASI [A+B] / 25x75 ■ 130

 su rete
(Mesh mounted)

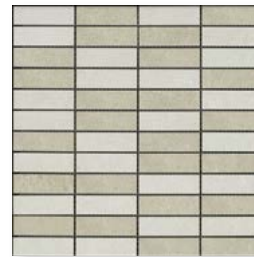

INVM01 - MOS.NATIVE MIX BEIGE / 30x30 ■ 25

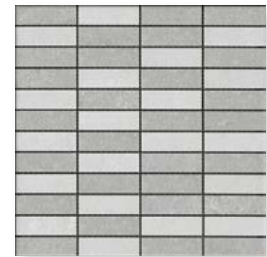

INVM02 - MOS.NATIVE MIX GRIGIO / 30x30 ■ 25

Cod.

*NB: prezzo per scatola completa.
*NB: price per full box.



8 pz.

NATIVE

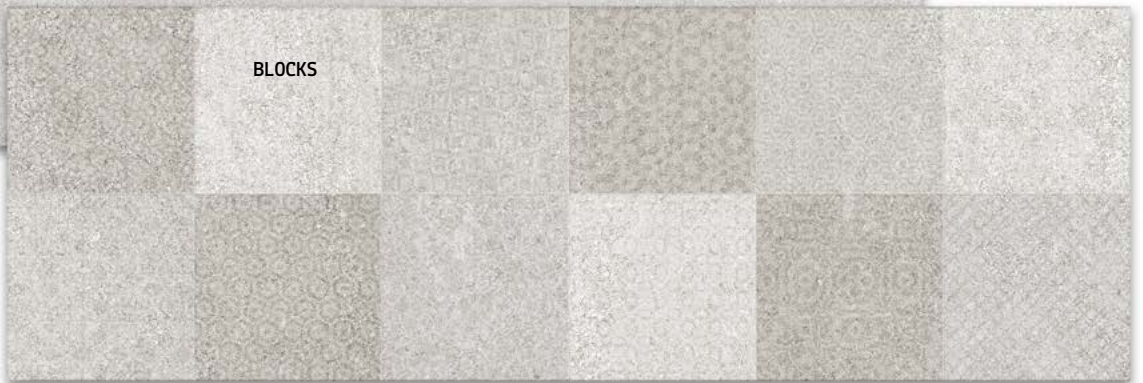

Web site
More info



ESSENZIALE

Bicottura tradizionale
Traditional double fired
Bi-cuisson traditionnelle
Zweibrandfliesen

Monocalibro / Monocaliber / Monocalibre / In einem werkmass

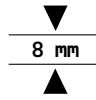

25x75
10"x29,5"



Size Formato	SCATOLE Boxes			PALETTE Pallets		
	Pz	m ²	Kg	Box	m ²	Kg
Cm 25x75						
BIANCO & GRIGIO	8	1,50	20,50	45	67,50	940,50
STRUTTURATI	8	1,50	20,50	45	67,50	940,50
FORME MIX	8	1,50	20,50	-	-	-
IMPERIAL [A+B]	8	1,5	20,50	-	-	-
Stick Blitz 1x75	8	-	0,70	-	-	-



Essenziale

ESSENZIALE

LAMIERA

ONDE

LINEE

FORME
MIX

COMP
IMPERIAL

Essenziale Bianco

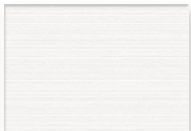
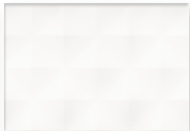
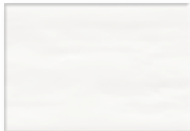

Essenziale Grigio





WALL TILE | **ESSENZIALE GRIGIO + COMP IMPERIAL** | 25x75



WALL TILE | **ONDE ESSENZIALE** | 25x75



WALL TILE | **LAMIERA ESSENZIALE** | 25x75

ESSENZIALE | 25x75

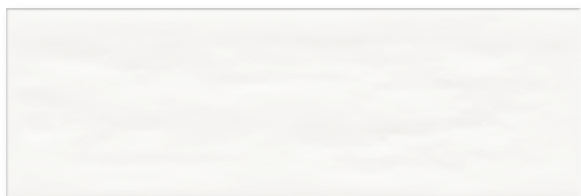

25x75 ESSENZIALE **BIANCO** IESR01 ■ 64

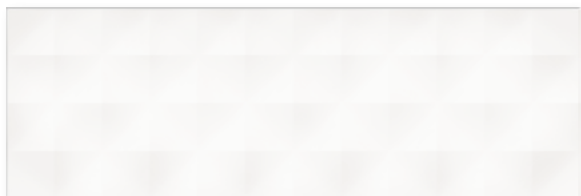

25x75 **LAMIERA** ESSENZIALE IESR02 ■ 66



25x75 **ONDE** ESSENZIALE IESR03 ■ 66

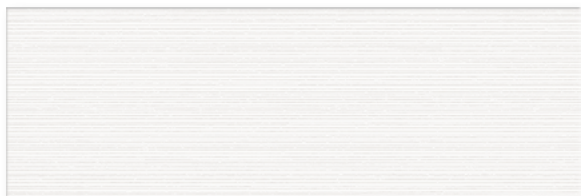

25x75 **LINEE** ESSENZIALE IESR04 ■ 66



25x75 ESSENZIALE **GRIGIO** IESR08 ■ 64



25x75 ESSENZIALE **FORME MIX** IESR06 ■ 71



UR015 Stick **BLITZ** SILVER 1x74,8 / 0,39"x29,5" ■ 28



25x75 ESSENZIALE **IMPERIAL [A+B]** IESR07 ■ 130

Ripetibili / Verticale / Orizzontale
Seamless / Vertical / Horizontal



8 pz x Box
1,5 Mg.

Cod.

*NB: prezzo per scatola completa.
*NB: price per full box.

[4 pz. A]
[4 pz. B]

ESSENZIALE



LAMIERA ESSENZIALE

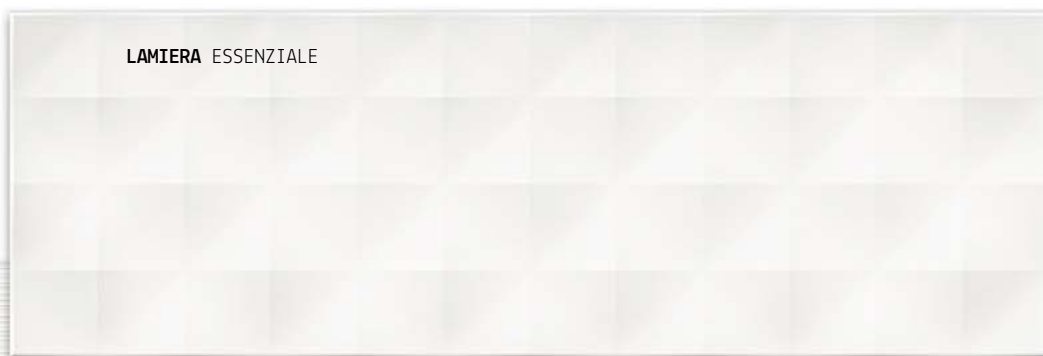

LINEE ESSENZIALE



ONDE ESSENZIALE



FORME MIX



COMPO IMPERIAL

Web site
More info



Pasta Bianca

White Body

NAIF

Rettificato

Rectified
Rectifié



25x75
10" x 29,5"



Pasta Bianca | White Body

L'impasto, essendo composto da materie prime ricche di ossido di titanio conferisce un grado di bianco alla piastrella che ricorda molto la preziosa porcellana. La bicottura in pasta bianca è un materiale pregiato che garantisce facilità di lavorazione.

The dough, being composed of raw materials rich in titanium oxide, gives a degree of whiteness to the tile which is very reminiscent of the refined porcelain. The double-fired white body is a precious material that guarantees ease of processing.

Die Mischung, die aus titanoxidreichen Rohstoffen besteht, verleiht der Fliese eine Nuance von Weiß, die sehr an kostbares Porzellan erinnert. Die Weißscherbige Zweibrandfliese ist ein wertvolles Material, das eine einfache Verarbeitung garantiert.

La pâte, constituée de matières premières riches en oxyde de titane, donne au carreau un degré de blancheur qui rappelle beaucoup la précieuse porcelaine. La biccuisson en pâte blanche est un matériau précieux qui garantit une facilité de traitement.

Size Formato

SCATOLE Boxes



PALETTE Pallets



Size Formato	Pz	m ²	Kg	Box	m ²	Kg
Cm 25x75						
25x75	8	1,50	20,50	45	67,50	940,50
CERCHI	8	1,50	20,50	45	67,50	940,50
COMP. FLORA	8	1,50	20,50	45	67,50	940,50
COMP. ACQUERELLO	8	1,50	20,50	45	67,50	940,50
COMP. CASCATA	4	0,75	9,60	-	-	-





Naif

NAIF

Juta Bianca

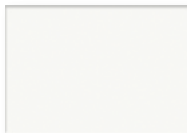

Acciaio



Aquamarine



Velluto Blu



Smeraldo



CERCHI

Dark



Light



COMP.
ACQUERELLO

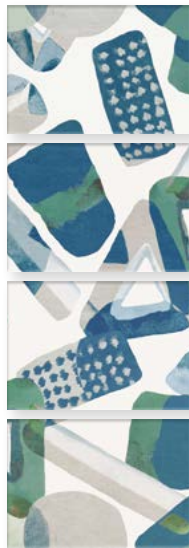

COMP. FLORA



COMP. CASCATA





WALL TILE | **CERCHI DARK + NAIF JUTA BIANCA + NAIF ACCIAIO** | 25x75



WALL TILE | **NAIF JUTA BIANCA + NAIF SMERALDO + COMPO FLORA** | 25x75



Rettificato

Rectified
Rectifié

NAIF | 25x75

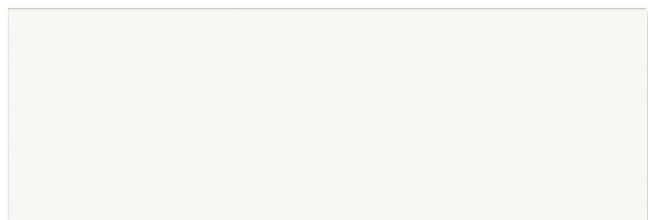
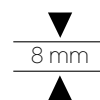

INAR01RV - NAIF - JUTA BIANCA / 25x75 / (PBRV) ■ 71



INAD02RV - CERCHI DARK / 25x75 / (PB) ■ 77



INAR02RV - NAIF - ACCIAIO / 25x75 / (PBRV) ■ 71



INAD01RV - CERCHI LIGHT / 25x75 / (PBRV) ■ 77

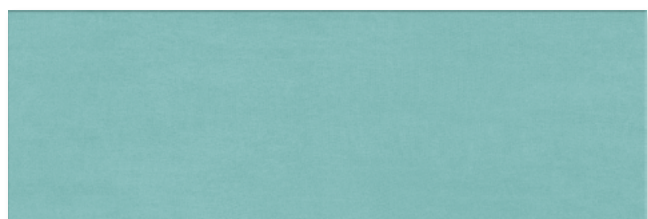

INAR03RV - NAIF - AQUAMARINE / 25x75 / (PBRV) ■ 73



INAR04RV - NAIF - VELLUTO BLU / 25x75 / (PBRV) ■ 73



INAR05RV - NAIF - SMERALDO / 25x75 / (PBRV) ■ 73



**VIRTUAL
SHOWROOM**



www.ideaceramica.net/naif



Rettificato
Rectified
Rectifié

NAIF | 25x75



INAD03RVC - COMP. **ACQUERELLO** [A+B+C+D] / 25x75 / (PB) ■ 134

*Nota: prezzo per scatola da 8 pz.



INAD05RVC - COMP. **FLORA** [A+B] / 25x75 / (PB)

■ 134

*Nota: prezzo per scatola da 8 pz.

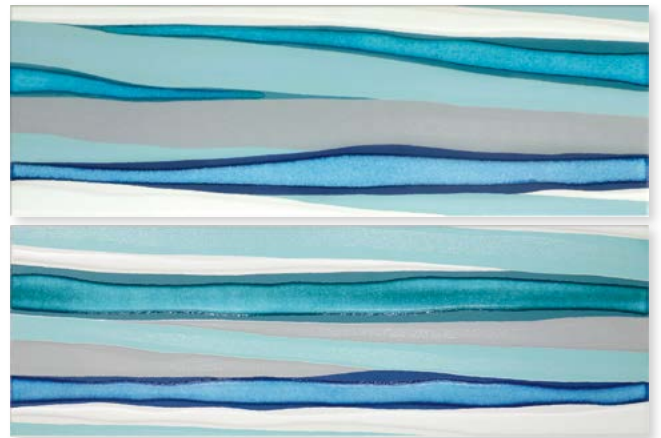
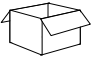

INAD04RVC - COMP. **CASCATA** [A+B] / 25x75 / (PB)

■ 118

*Nota: prezzo per scatola da 4 pz.

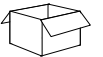

Cod.

*NB: prezzo per scatola completa.
*NB: price per full box.





WALL TILE | **NAIF VELLUTO BLU + NAIF JUTA BIANCA + COMPO CASCATA** | 25x75

NAIF



Cerchi Light



Cascata



Acquerello

Web site
More info

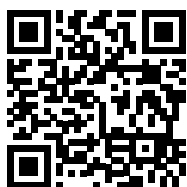

Pasta Bianca

White Body

Glossy
LUCIDO

Fiji

Rettificato
Rectified
Rectifié



25x75
10" x 29,5"



Pasta Bianca | White Body

L'impasto, essendo composto da materie prime ricche di ossido di titanio conferisce un grado di bianco alla piastrella che ricorda molto la preziosa porcellana. La bicottura in pasta bianca è un materiale pregiato che garantisce facilità di lavorazione.

The dough, being composed of raw materials rich in titanium oxide, gives a degree of whiteness to the tile which is very reminiscent of the refined porcelain. The double-fired white body is a precious material that guarantees ease of processing.

Die Mischung, die aus titanoxidreichen Rohstoffen besteht, verleiht der Fliese eine Nuance von Weiß, die sehr an kostbares Porzellan erinnert. Die Weißscherbige Zweibrandfliese ist ein wertvolles Material, das eine einfache Verarbeitung garantiert.

La pâte, constituée de matières premières riches en oxyde de titane, donne au carreau un degré de blancheur qui rappelle beaucoup la précieuse porcelaine. La biccuisson en pâte blanche est un matériau précieux qui garantit une facilité de traitement.

Size Formato	SCATOLE Boxes			PALETTE Pallets		
	Pz	m ²	Kg	Box	m ²	Kg
Cm 25x75						
25X75	8	1,50	20,50	45	67,50	940,50
EDERA 3D	8	1,50	20,50	45	67,50	940,50
MURANO	8	1,50	20,50	45	67,50	940,50
COMP. PETALI	6	-	14,40	-	-	-
COMP. VETRO	4	-	9,60	-	-	-
Stick FIJI 0,5x75	10	-	0,08	-	-	-





Glossy
LUCIDO

Fiji

FIJI

EDERA

MURANO

COMP. PETALI

Bianco

Bianco

Bianco

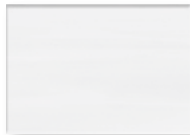

Acqua

Acqua

Acqua



Blu Notte

Blu Notte

Blu Notte



Menta

Menta



Grigio

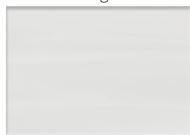

COMP. VETRO





WALL TILE | **Fiji MENTA + Fiji BIANCO + COMP. VETRO** | 25x75



WALL TILE | **MURANO BIANCO + MURANO ACQUA** | 25x75



Rettificato
Rectified
Rectifié

Fiji | 25x75

Glossy
LUCIDO

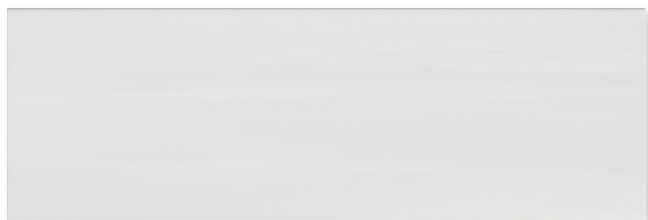
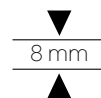

IFIRO2RV - FIJI - GRIGIO / 25x75 / (PBRV) ■ 73



IFIR10RV - EDERA 3D BIANCO / 25x75 / (PBRV) ■ 74

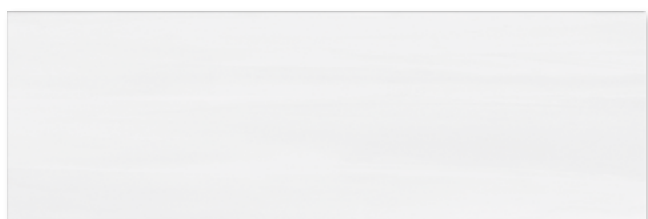

IFIRO1RV - FIJI - BIANCO / 25x75 / (PBRV) ■ 73



IFIR30RV - EDERA 3D MENTA / 25x75 / (PBRV) ■ 76



IFIRO3RV - FIJI - MENTA / 25x75 / (PBRV) ■ 75



IFIR40RV - EDERA 3D ACQUA / 25x75 / (PBRV) ■ 76



IFIRO4RV - FIJI - ACQUA / 25x75 / (PBRV) ■ 75



IFIR50RV - EDERA 3D BLU NOTTE / 25x75 / (PB) ■ 76



IFIRO5RV - FIJI - BLU NOTTE / 25x75 / (PBRV) ■ 75

IFIS04 - FIJI - STICK GRIGIO / 0,5x75 ■ 25

IFIS02 - FIJI - STICK MENTA / 0,5x75 ■ 25

IFIS01 - FIJI - STICK ACQUA / 0,5x75 ■ 25

IFIS03 - FIJI - STICK NOTTE / 0,5x75 ■ 25



Rettificato
Rectified
Rectifié

Fiji | 25x75

✦ **Glossy**
LUCIDO

▼
8 mm
▲

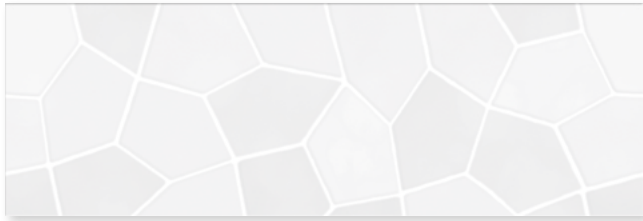

IFID01RV - MURANO BIANCO / 25x75 / (PBRV) ■ 77



IFID02RV - MURANO ACQUA / 25x75 / (PBRV) ■ 77



IFID03RV - MURANO NOTTE / 25x75 / (PBRV) ■ 77



IFID04RVC - FIJI - COMP. PETALI [A+B+C] 25x75 / (PB) ■ 130

*Nota: prezzo per scatola da 6 pz.



**VIRTUAL
SHOWROOM**



www.ideaceramica.net/showroom-360-fiji



IFID05RVC - FIJI - COMP. VETRO [A+B] 25x75 / (PB) ■ 118

*Nota: prezzo per scatola da 4 pz.



Cod. *NB: prezzo per scatola completa.
*NB: price per full box.

Web site
More info



WHITE PROJECT

Pasta Bianca

Monocalibro / Monocaliber / Monocalibre / In einem werkmass

White Body

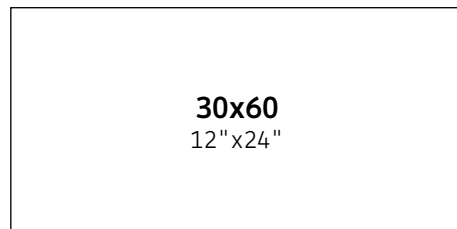

Pasta Bianca | White Body

L'impasto, essendo composto da materie prime ricche di ossido di titanio conferisce un grado di bianco alla piastrella che ricorda molto la preziosa porcellana. La bicottura in pasta bianca è un materiale pregiato che garantisce facilità di lavorazione.

The dough, being composed of raw materials rich in titanium oxide, gives a degree of whiteness to the tile which is very reminiscent of the refined porcelain. The double-fired white body is a precious material that guarantees ease of processing.

Die Mischung, die aus titanoxidreichen Rohstoffen besteht, verleiht der Fliese eine Nuance von Weiß, die sehr an kostbares Porzellan erinnert. Die Weißscherbige Zweibrandfliese ist ein wertvolles Material, das eine einfache Verarbeitung garantiert.

La pâte, constituée de matières premières riches en oxyde de titane, donne au carreau un degré de blancheur qui rappelle beaucoup la précieuse porcelaine. La biccuisson en pâte blanche est un matériau précieux qui garantit une facilité de traitement.



FORMATO Size	SPESSORE Thickness	SCATOLE Boxes			PALETTE Pallets		
cm	mm	pcs	m ²	kg	box	m ²	kg
30x60	7	8	1,44	18,20	72	103,68	1330



White Project



Seta

◆◆ Matt

◆◆ Glossy
LUCIDO

DECO

◆◆ Matt

SETA

White LUX

Grigio ◆◆ Matt

White MATT

Pergamon

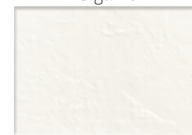
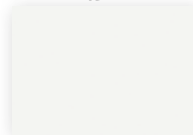
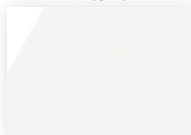

L36 Beige

Beige ◆◆ Matt

M36 Beige

Grau

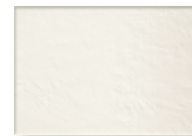
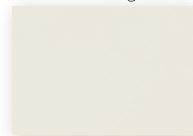
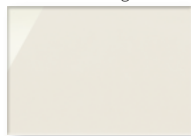

L36 Grey

M36 Grey

Weiss

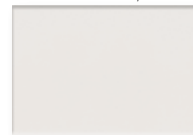

BUMP

BUMP

L36 Bump LUX

M36 Bump MATT

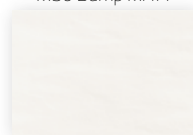



WALL TILE | **WHITE MATT** | 30x60



WALL TILE | **WHITE MATT** | 30x60



WHITE PROJECT | 30x60



◆ Glossy
LUCIDO

◆ Matt

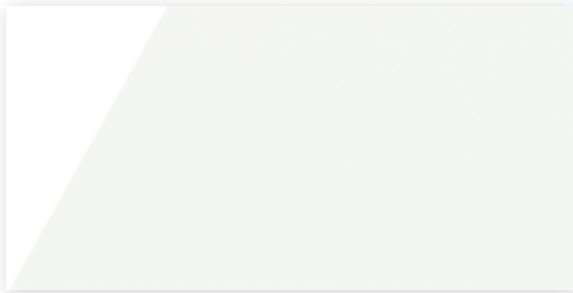

MWBI02M White Project WHITE LUX / 30x60 ■ 53

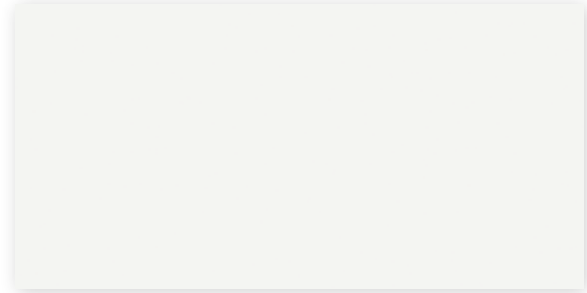

MWBI01M White Project WHITE MATT / 30x60 ■ 53



MWBI08M White Project L36BEIGE LUX / 30x60 ■ 53

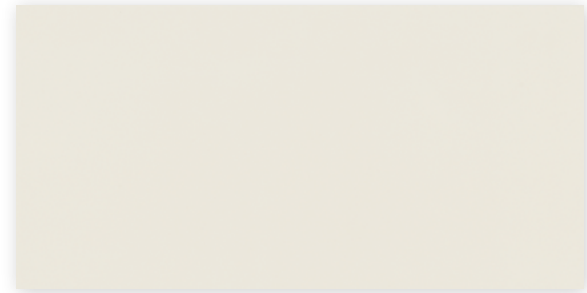

MWBI06M White Project M36BEIGE MATT / 30x60 ■ 53



MWBI07M White Project L36GREY LUX / 30x60 ■ 53

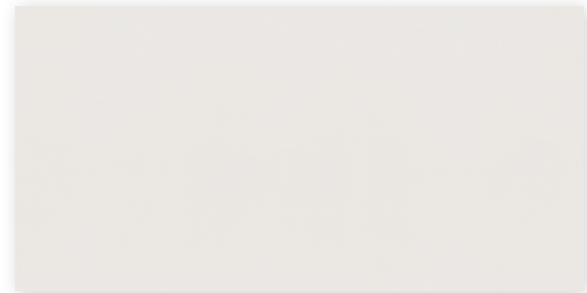

MWBI05M White Project M36GREY MATT / 30x60 ■ 53

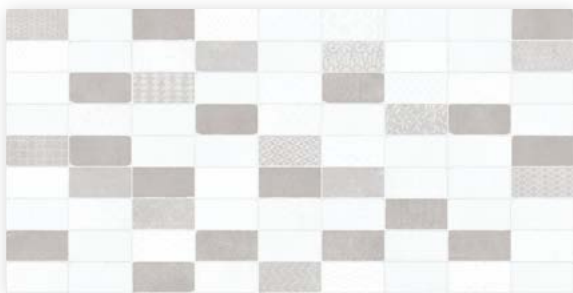

MWBI10M White Project M36 DECO GRIGIO / 30x60 ■ 64



MWBI09M White Project M36 DECO BEIGE / 30x60 ■ 64

◆ Matt

◆ Matt



MWBI04M White Project L36BUMP LUX / 30x60 ■ 53

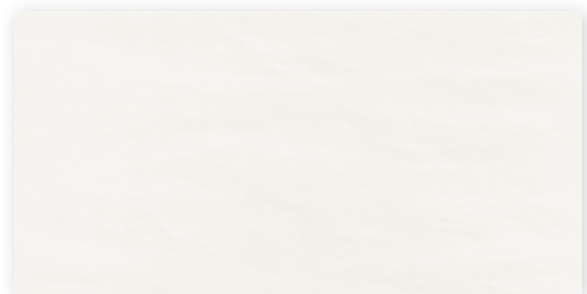

MWBI03M White Project M36BUMP MATT / 30x60 ■ 53

Bump

Bump



SETA | 30x60



◆ ◆ **Matt**



IWSI01M Seta **WEISS** / 30x60

■ 59



IWSI02M Seta **GRAU** / 30x60

■ 59



IWSI03M Seta **PERGAMON** / 30x60

■ 59

Matching Stick: 0,5x60



10 pz.

BS001 Stick **CHIC SILVER** / 0,5x60

■ 33

BS002 Stick **CHIC GOLD** / 0,5x60

■ 33

Web site
More info

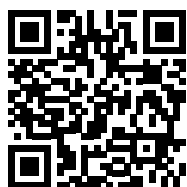

Glossy
LUCIDO

PORTOFINO

Bicottura tradizionale
Traditional double fired
Bi-cuisson traditionnelle
Zweibrandfliesen

Monocalibro / Monocaliber / Monocalibre / In einem werkmass

▼
8 mm
▲

25x60
10" x 24"



FORMATO Size		SPESSORE Thickness	SCATOLE Boxes			PALETTE Pallets		
cm		mm	pcs	m ²	kg	box	m ²	kg
25x60		8	10	1,50	19,50	48	72,00	954
KLAUS	25x60	8	10	1,50	19,50	48	72,00	954
CASCATA	KLAUS 25x60	8	10	1,50	19,50	48	72,00	954
MUMI + AURORA		8	10	1,50	19,50	48	72,00	954



Glossy
LUCIDO

Portofino

PORTOFINO

Azzurro



Smeraldo



Bianco

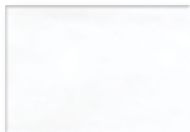

DEC KLAUS

Azzurro



Smeraldo



CASCATA KLAUS

Azzurro

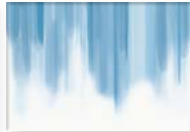

Smeraldo



DEC MUMM



DEC AURORA





WALL TILE | PORTOFINO BIANCO + DEC. KLAUS SMERALDO + CASCATA KLAUS SMERALDO | 25x60



WALL TILE | PORTOFINO BIANCO + DEC. KLAUS AZZURRO + CASCATA KLAUS CASCATA | 25x60



WALL TILE | **PORTOFINO SMERALDO + DEC. KLAUS SMERALDO** | 25x60



WALL TILE | PORTOFINO AZZURRO + DEC. KLAUS AZZURRO | 25x60



WALL TILE | DEC. MUMM | 25x60

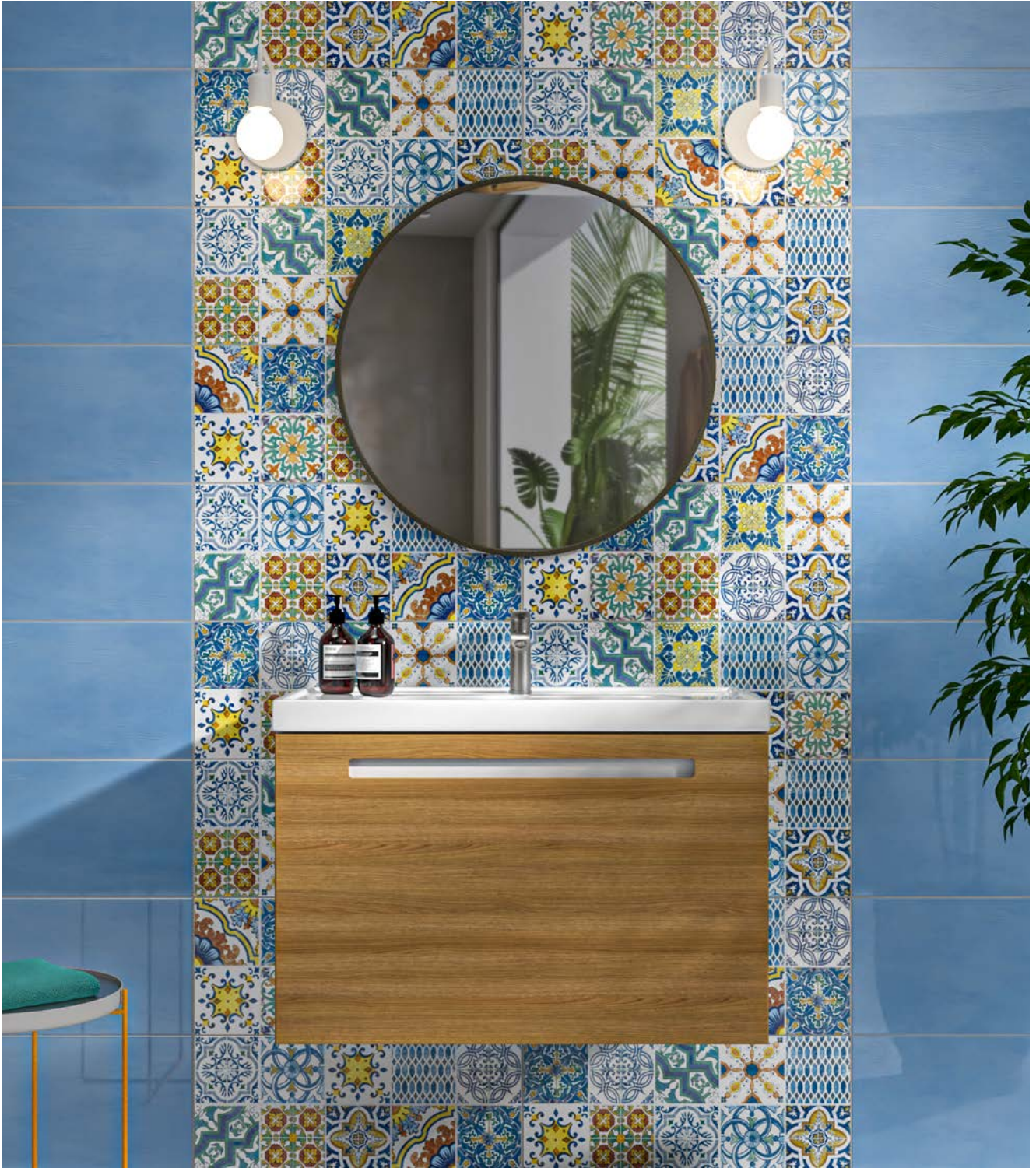

WALL TILE | PORTOFINO AZZURRO + DEC. AURORA | 25x60

PORTOFINO | 25x60

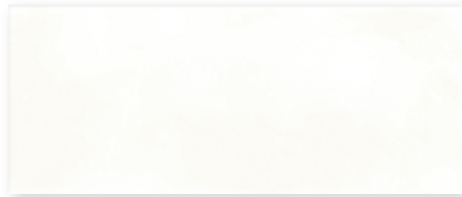
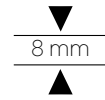

IPFR01 - PORTOFINO BIANCO / 25x60 ■ 62



IPFR01 - PORTOFINO BIANCO / 25x60 ■ 62



IPFD01 - PORTOFINO DEC. KLAUS AZZURRO
25X60 ■ 73



IPFD04 - PORTOFINO DEC. KLAUS SMERALDO
25X60 ■ 73

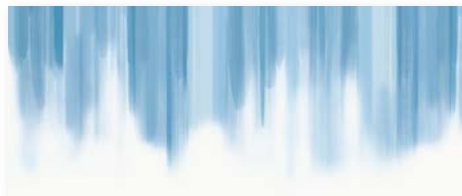

IPFD05 - PORTOFINO / 25x60
CASCATA KLAUS AZZURRO ■ 77



IPFD06 - PORTOFINO / 25x60
CASCATA KLAUS SMERALDO ■ 77



IPFR03 - PORTOFINO AZZURRO / 25x60 ■ 62



IPFR02 - PORTOFINO SMERALDO / 25x60 ■ 62



IPFD03 - PORTOFINO DEC. AURORA / 25x60 ■ 73



IPFD02 - PORTOFINO DEC. MUMM / 25x60 ■ 73

MATCHING FLOOR | Pag. 290

PALINURO

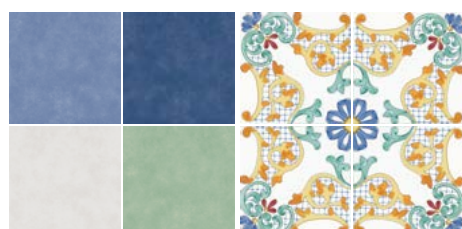

Web site
More info



PORTOFINO

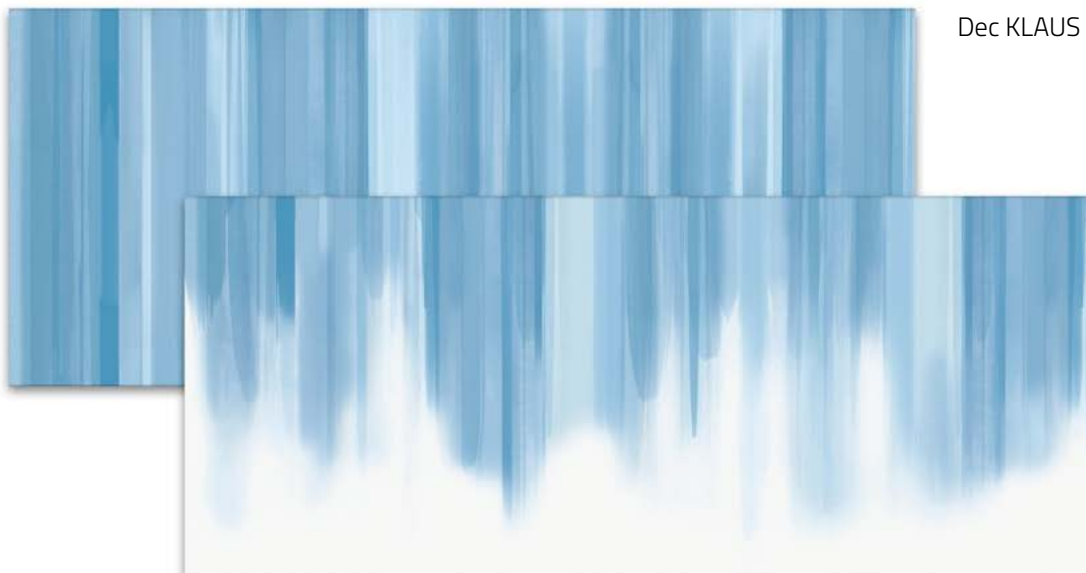

Dec KLAUS



CASCATA KLAUS

Dec AURORA



Dec MUMM

Web site
More info



KI MATCH

Bicottura tradizionale
Traditional double fired
Bi-cuisson traditionnelle
Zweibrandfliesen



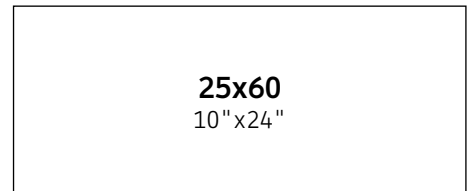
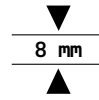







Monocalibro / Monocaliber / Monocalibre / In einem werkmass

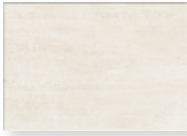

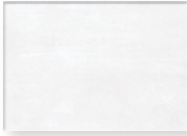
FORMATO Size	SPESSORE Thickness	SCATOLE Boxes			PALETTE Pallets		
		pcs	m ²	kg	box	m ²	kg
cm	mm						
25x60	8	10	1,50	19,50	48	72,00	954
DECORI	8	10	1,50	19,50	48	72,00	954



Ki Match

FONDI	KENZIA	
Grey 	Grey 	
Beige 	Beige 	
White 		SKETCH UNI
Mud 		PLANK
Navy 		



WALL TILE | **KI MATCH GREY + KENZIA GREY** | 25x60



WALL TILE | **KI MATCH WHITE + KI MATCH MUD + PLANK MUD** | 25x60

KI MATCH | 25x60

▼
8 mm
▲

FONDI



25x60 GREY
IKYR03 ■ 56



25x60 BEIGE
IKYR02 ■ 56



25x60 WHITE
IKYR01 ■ 56



25x60 MUD
IKYR04 ■ 56



25x60 NAVY
IKYR05 ■ 56

DECORI



25x60 KENZIA GREY
IKYD05 / 8 faces ■ 63



25x60 KENZIA BEIGE
IKYD04 / 8 faces ■ 63



25x60 SKETCH UNI
IKYD03 / 8 faces ■ 63



25x60 PLANK MUD
IKYD01 / 8 faces ■ 63



25x60 PLANK NAVY
IKYD02 / 8 faces ■ 63

KI MATCH | 25x60

WARM



Kenzia

COLD



Sketch UNI



Plank



KI MATCH | 25x60

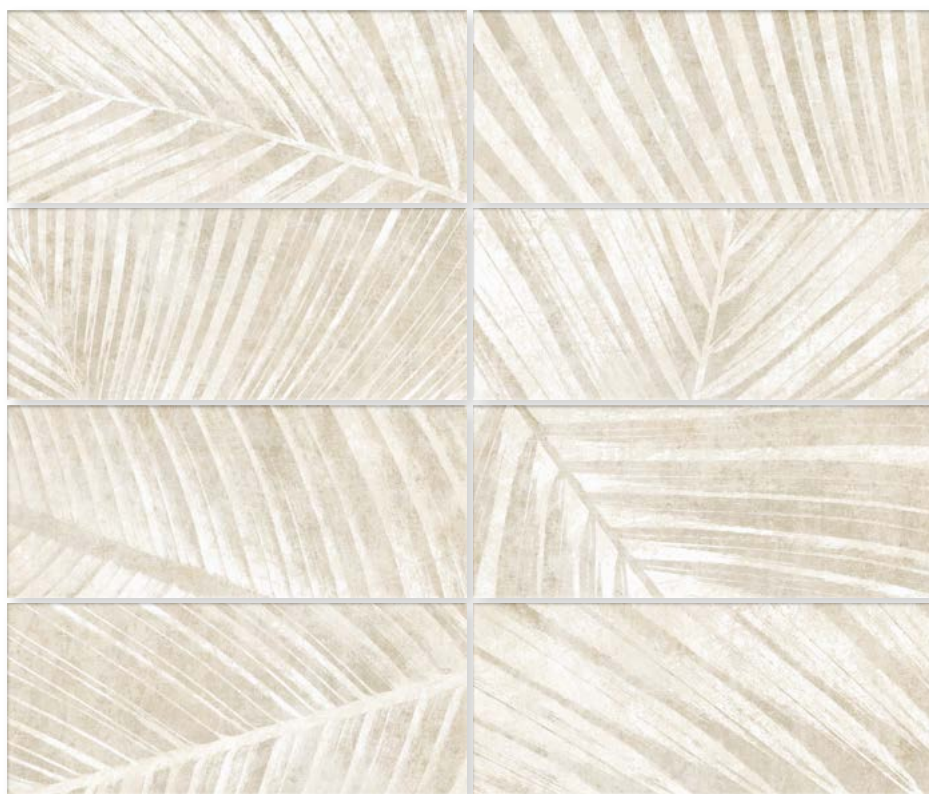

Kenzia / 8 faces

KI MATCH | 25x60

Plank / 8 faces

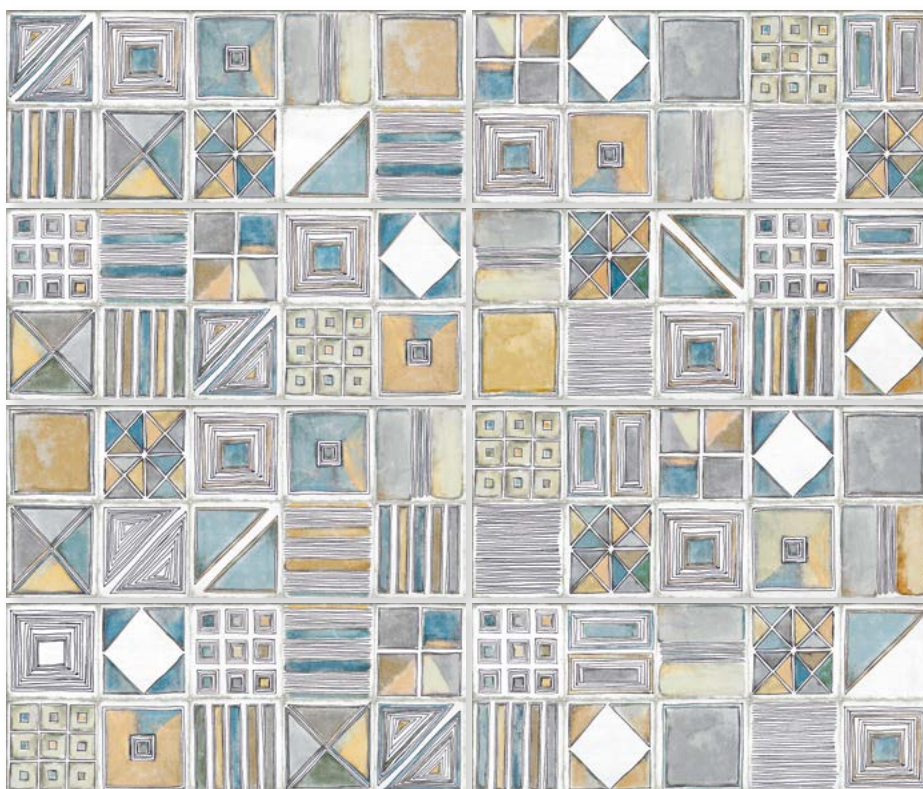

Sketch UNI / 8 faces



WALL TILE | **KI MATCH WHITE + KI MATCH NAVY + PLANK NAVY** | 25x60

KI MATCH



Sketch UNI



Plank Mud



Kenzia Beige



Kenzia Grey



Plank Navy

Web site
More info



VERNISSAGE

Bicottura tradizionale
Traditional double fired
Bi-cuisson traditionnelle
Zweibrandfliesen

Monocalibro / Monocaliber / Monocalibre / In einem werkmass

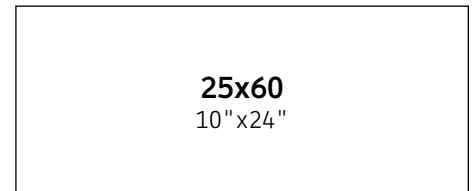
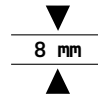

FORMATO Size	SPESSORE Thickness	SCATOLE Boxes			PALETTE Pallets		
		pcs	m ²	kg	box	m ²	kg
cm 25x60	mm 8	10	1,50	19,50	48	72,00	954
COMP. TROPICANA	8	10	1,50	19,50	-	-	-



Vernissage

	VERNISSAGE	TRAME	ACRILICO
	Porpora	Porpora	Porpora
			
PATTERN			
Denim	Denim	Denim	Denim
			
Cenere	Cenere	Cenere	
			
Oliva	Oliva	Oliva	TROPICANA
			
Ecrù	Ecrù	Ecrù	
			
Neve	Neve	Neve	
			



WALL TILE | **COMPO TROPICANA + TRAME OLIVA** | 25x60



WALL TILE | **TRAME CENERE + PATTERN MIX CENERE** | 25x60

VERNISSAGE | 25x60

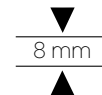

IVA300 Vernissage **OLIVA** / 25x60 ■ 64



IVA350 TRAME **OLIVA** / 25x60 ■ 66



IVA600 Vernissage **CENERE** / 25x60 ■ 62



IVA650 TRAME **CENERE** / 25x60 ■ 66



IVA400 Vernissage **DENIM** / 25x60 ■ 64



IVA450 TRAME **DENIM** / 25x60 ■ 66

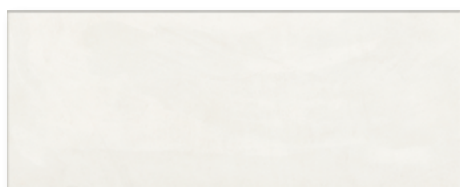

IVA100 Vernissage **NEVE** / 25x60 ■ 62

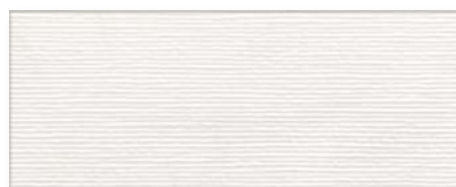

IVA150 TRAME **NEVE** / 25x60 ■ 66



IVA500 Vernissage **PORPORA** / 25x60 ■ 64

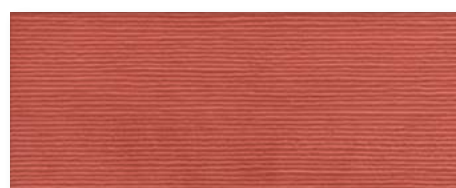

IVA550 TRAME **PORPORA** / 25x60 ■ 66

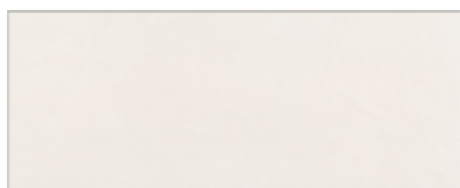

IVA200 Vernissage **ECRU** / 25x60 ■ 62



IVA250 TRAME **ECRU** / 25x60 ■ 66

VERNISSAGE | 25x60

TROPICANA



IVAR25 COMPOSIZIONE TROPICANA
25x60 [10 facce]

■ 126



IVAR22 PATTERN MIX CENERE / 25x60 ■ 73

PATTERN



IVAR21 PATTERN MIX DENIM / 25x60 ■ 73



IVAR23 ACRILICO DENIM / 25x60 ■ 73

ACRILICO



IVAR24 ACRILICO PORPORA / 25x60 ■ 73

Matching Stick: 0,5x60

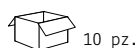

10 pz.

BS001 Stick CHIC SILVER / 0,5x60 ■ 33

BS002 Stick CHIC GOLD / 0,5x60 ■ 33



TROPICANA | 25x60



01 A * La prima da posare in angolo a SX.
 01 A * The first to be placed in the left corner.



125 cm

120 cm



10 pz x Box

IVAR25 COMPOSIZIONE TROPICANA / 25x60 / 10 Facce

10 pz. (120x125 cm) 1,5 mq.
 10 pz. per box (dalla 01 alla 10)

Composizione 10 Facce / 10 Tiles

120x125 h / Ripetibili / Verticale / Orizzontale
 120x125 h / Seamless / Vertical / Horizontal

*Prezzo per scatola da 10 pz. ■ 126

Cod. *NB: prezzo per scatola completa.
 *NB: price per full box.

10 pz x Box

10 pz x Box



Verticale

125 cm

250 cm

125 cm

120 cm

240 cm

Orizzontale

120 cm

120 cm

125 cm



10 pz x Box

10 pz x Box

ACRILICO

PATTERN



TRAME

VERNISSAGE



TROPICANA



TRAME



Web site
More info



BEST

Bicottura tradizionale
Traditional double fired
Bi-cuisson traditionnelle
Zweibrandfliesen

Monocalibro / Monocaliber / Monocalibre / In einem werkmass

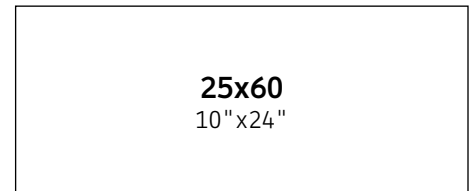

Size Formato	SCATOLE Boxes			PALETTE Pallets		
	Pz	m ²	Kg	Box	m ²	Kg
Cm 25x60						
25X60	9	1,35	19,18	48	64,80	938
LIST. CHIC 4x60	6	0,16	2,47	-	-	-
STICK CHIC 0,5x60	10	-	0,09	-	-	-



Best

BEST

WALL

SCULPTURE

Ice

Ice

Ice

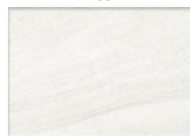

Ivory

Ivory

Ivory

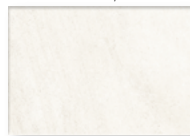

Ultra White

Ultra White

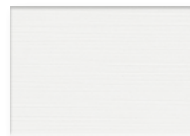



WALL TILE | **BEST IVORY + SCULPTURE IVORY + CHIC IVORY** | 25x60



WALL TILE | **SCULPTURE ULTRA WHITE + BEST ULTRA WHITE** | 25x60

BEST | 25x60

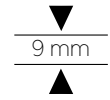

BS100 Best **ICE** / 25x60 **56**



BS400 Best **IVORY** / 25x60 **56**

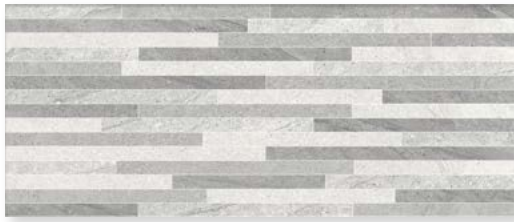

BS300 WALL **ICE** / 25x60 **63**



BS600 WALL **IVORY** / 25x60 **63**



BS200 SCULPTURE **ICE** / 25x60 **63**



BS500 SCULPTURE **IVORY** / 25x60 **63**



BS700 Best **ULTRA WHITE** / 25x60 **56**



BS101 LIST. CHIC **ICE** / 4x60 **28**



BS401 LIST. CHIC **IVORY** / 4x60 **28**



BS701 LIST. CHIC **ULTRA WHITE** / 4x60 **28**



BS800 SCULPTURE **ULTRA WHITE** / 25x60 **63**



BS001 STICK CHIC **SILVER** / 0,5x60 **33**



BS002 STICK CHIC **GOLD** / 0,5x60 **33**

BEST



Sculpture **ULTRA WHITE**



SCULPTURE

WALL

Web site
More info

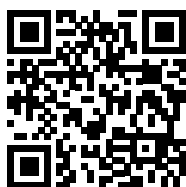

MARVEL

Bicottura tradizionale
Traditional double fired
Bi-cuisson traditionnelle
Zweibrandfliesen

Monocalibro / Monocaliber / Monocalibre / In einem werkmass

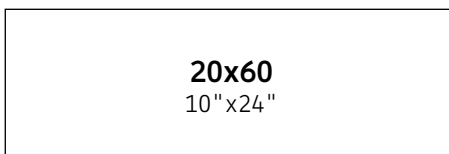
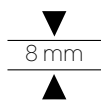



Esagono



Muretto



FORMATO Size	SPESSORE Thickness	SCATOLE Boxes					
			pcs	m ²	kg	box	m ²
20x60	8	12	1,44	18,50	56	80,64	1055
MURETTO	8	12	1,44	18,50	56	80,64	1055
ESAGONO	8	12	1,44	18,50	56	80,64	1055
45x45 Floor	8,2	8	1,66	26,24	48	79,68	1260



Marvel



MATCHING FLOOR | Pag. 314

Riflessi | 45x45

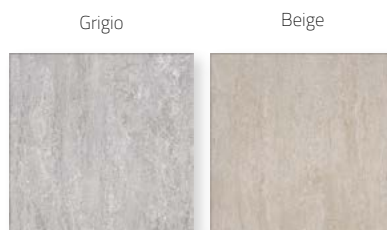



WALL TILE | **MARVEL GRIGIO + MARVEL GRIGIO SCURO + MURETTO GRIGIO** | 20x60

WALL TILE | **ESAGONO GRIGIO** | 20x60

MARVEL | 20x60

▼
8 mm
▲



IMAR03 - MARVEL GRIGIO / 20x60 ■ 56



IMAR01 - MARVEL BEIGE / 20x60 ■ 56



IMAR04 - MARVEL GRIGIO SCURO / 20x60 ■ 56



IMAR02 - MARVEL BEIGE SCURO / 20x60 ■ 56



IMAR21 - MARVEL MURETTO GRIGIO / 20x60 ■ 63



IMAR20 - MARVEL MURETTO BEIGE / 20x60 ■ 63



IMAR11 - MARVEL ESAGONO GRIGIO / 20x60 ■ 63



IMAR10 - MARVEL ESAGONO BEIGE / 20x60 ■ 63

MATCHING FLOOR | Pag. 314

RIFLESSI | 45x45

▼
8,2 mm
▲

Pavimento



FRGR425 - RIFLESSI GRIGIO / 45,5x45,5 ■ 50



FRBE425 - RIFLESSI BEIGE / 45,5x45,5 ■ 50

Web site
More info



Glossy
LUCIDO

SHINE

Bicottura tradizionale
Traditional double fired
Bi-cuisson traditionnelle
Zweibrandfliesen

Monocalibro / Monocaliber / Monocalibre / In einem werkmass

▼
8 mm
▲



20x60
10"x24"

Mosaico



Muretto



FORMATO Size	SPESSORE Thickness	SCATOLE Boxes			PALETTE Pallets		
cm	mm	pcs	m ²	kg	box	m ²	kg
20x60	8	12	1,44	18,50	56	80,64	1055
MURETTO	8	12	1,44	18,50	56	80,64	1055
MOSAICO	8	12	1,44	18,50	56	80,64	1055
45x45 Floor	8,2	8	1,66	26,24	48	79,68	1260





★ **Glossy**
 LUCIDO **Shine**

SHINE		MURETTO	MOSAICO
UNI	Grigio	Grigio	Grigio
			
UNI	Beige	Beige	Beige
			

MATCHING FLOOR | Pag. 314

Riflessi | 45x45

Grigio	Beige
	



WALL TILE | SHINE BEIGE + SHINE UNI + MURETTO BEIGE | 20x60



ISHR01 - SHINE UNI BIANCO / 20x60 ■ 56



ISHR01 - SHINE UNI BIANCO / 20x60 ■ 56



ISHR03 - SHINE GRIGIO / 20x60 ■ 56



ISHR02 - SHINE BEIGE / 20x60 ■ 56



ISHR31 - SHINE MURETTO GRIGIO / 20x60 ■ 63



ISHR21 - SHINE MURETTO BEIGE / 20x60 ■ 63



ISHR30 - SHINE MOSAICO GRIGIO / 20x60 ■ 63



ISHR20 - SHINE MOSAICO BEIGE / 20x60 ■ 63

MATCHING FLOOR | Pag. 314

RIFLESSI | 45x45

Pavimento



FRGR425 - RIFLESSI GRIGIO / 45,5x45,5 ■ 50



FRBE425 - RIFLESSI BEIGE / 45,5x45,5 ■ 50

LUCE LUX & LUCE MATT

Bicottura tradizionale
Traditional double fired
Bi-cuisson traditionnelle
Zweibrandfliesen

Monocalibro / Monocaliber / Monocalibre / In einem werkmass

LUCE LUX

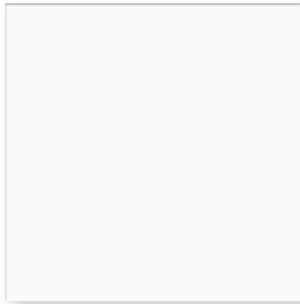

ILUR01 LUCE LUX / 20x20 ■ 39



ILUR10 FORM MINORI / 20x20 ■ 64

MINORI
FORM

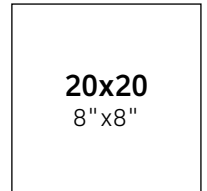

◆ Glossy
LUCIDO

33 FACCE

LUCE MATT

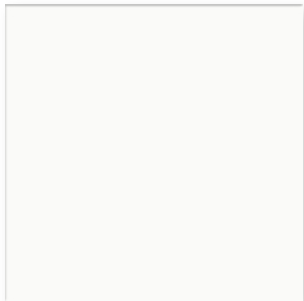

ILUR02 LUCE MATT / 20x20 ■ 39



Cementine
MIX

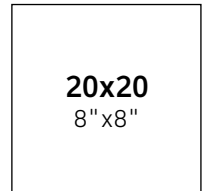

◆ Matt

28 FACCE

Web site
More info



FORMATO
Size

SPESORE
Thickness

SCATOLE
Boxes



PALETTE
Pallets



cm	mm	pcs	m ²	kg	box	m ²	kg
20x20 LUCE LUX	8	30	1,20	16,23	72	86,40	1187
20x20 LUCE MATT	8	30	1,20	16,23	72	86,40	1187
20X20 CEMENTINE MIX	8	30	1,20	16,23	72	86,40	1187
20X20 MINORI FORM	8	30	1,20	16,23	72	86,40	1187





Luce LUX | 20x20

▼
8 mm
▲



33 FACCE DIFFERENTI / 33 FACES



Luce MATT | 20x20

▼
8mm
▲



28 FACCE DIFFERENTI / 28 FACES





idea
ceramica

PAVIMENTO | WOOD

Web site
More info



V2



PEI 4

TENDER

Gres Porcellanato
Porcelain stoneware
Grès cérame
Feinsteinzeug

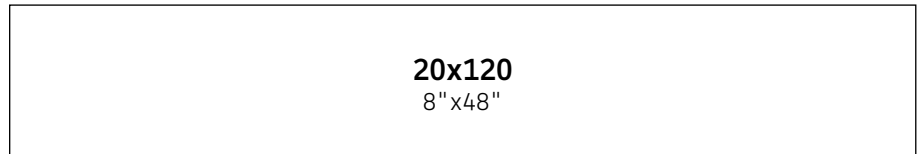

RETTIFICATO / R9 + R11



FORMATO Size	SPESSORE Thickness	SCATOLE Boxes			PALETTE Pallets		
		pcs	m ²	kg	box	m ²	kg
20x120 RET	9,5	6	1,44	28,90	36	51,84	1060
20x120 GRIP	9,5	6	1,44	28,90	36	51,84	1060



Tender



Acero

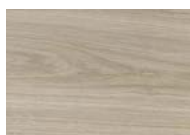

Nocciola



Avana



Rovere

R9 + R11



Mogano

R9 + R11



FLOOR | TENDER **ACERO**





FLOOR | TENDER **AVANA**



FLOOR | TENDER **ROVERE**





20x120

Tender

Gres Porcellanato / Porcelain stoneware / Grès cérame / Feinsteinzeug



RETTIFICATO

Acero

Acero



ITEP01 Tender **ACERO** / 20x120 ■ 83

Nocciola

Nocciola



ITEP05 Tender **NOCCIOLA** / 20x120 ■ 83

Avana

Avana



ITEP02 Tender **AVANA** / 20x120 ■ 83

Rovere

R9 + R11

Rovere



ITEP07 Tender **ROVERE** / **GRIP** / **R11** / 20x120 ■ 83

ITEP03 Tender **ROVERE** / 20x120 ■ 83

Mogano

R9 + R11

Mogano

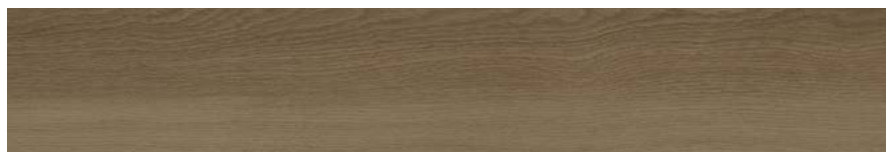

ITEP06 Tender **MOGANO** / **GRIP** / **R11** / 20x120 ■ 83

ITEP04 Tender **MOGANO** / 20x120 ■ 83

Outdoor / Esterno

↓ FLOOR / Tender MOGANO / RETT / GRIP R11 / 20x120 ↓



Consigli di posa / Conseils de pose / Verlegeempfehlungen

Installation advise

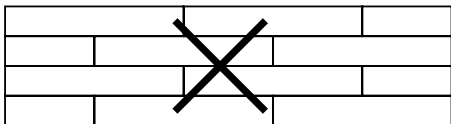

NO 50%

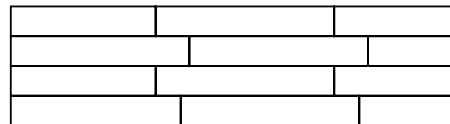

OK

Pezzi Speciali

[Special items]



24

Battiscopa
6,5x120
pcs/box 8
Kg 15

ITEB01 Tender ACERO
ITEB02 Tender AVANA
ITEB03 Tender ROVERE
ITEB04 Tender MOGANO
ITEB05 Tender NOCCIOLA



Avana



Mogano



Rovere

TENDER

Acero



Nocciola

Web site
More info



OAK

Gres Porcellanato
Porcelain stoneware
Grès cérame
Feinsteinzeug

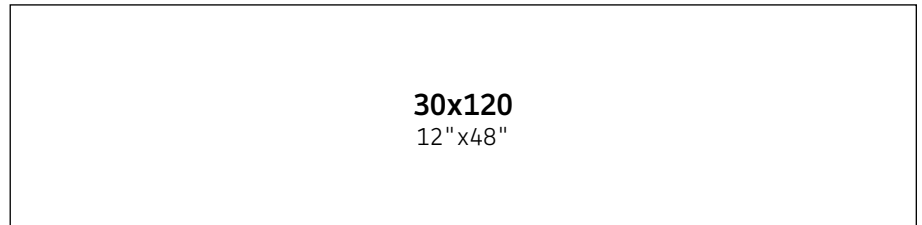
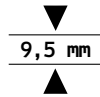

30x120
12"x48"

RETTIFICATO / R9

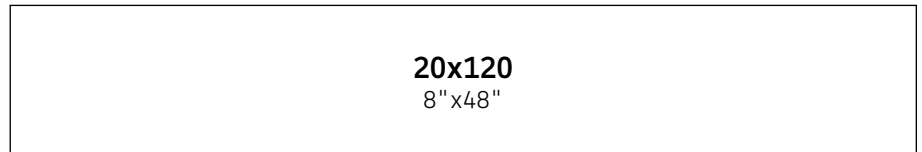
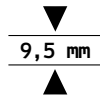

20x120
8"x48"

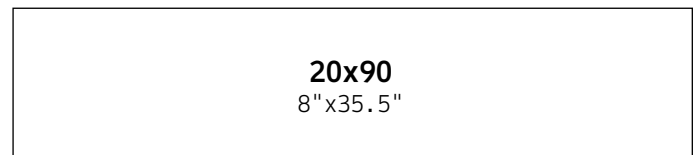
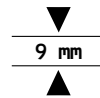

RETTIFICATO / R9 + R11



20x90
8"x35.5"

NATURALE / R9 + R11



FORMATO Size	SPESSORE Thickness	SCATOLE Boxes			PALETTE Pallets		
cm	mm	pcs	m ²	kg	box	m ²	kg
30x120 RET	9,5	4	1,44	28,40	36	51,84	1040
20x120 RET	9,5	6	1,44	28,90	36	51,84	1060
20x90 NAT	9	6	1,10	19,60	60	66,00	1195
20x90 GRIP	9	6	1,10	19,60	60	66,00	1195



Oak



Blonde



Natural



Red



Dark



White



FLOOR | OAK **DARK**



FLOOR | OAK **NATURAL**

30x120
20x120

Oak

Gres Porcellanato / Porcelain stoneware / Grès cérame / Feinsteinzeug



RETTIFICATO

Blonde

IOKP210CC Oak BLONDE / 30x120 ■ 83



IOKP200C Oak BLONDE / 20x120 ■ 83

IOKP220C Oak BLONDE / Grip R11 / 20x120 ■ 83

Natural

IOKP310CC Oak NATURAL / 30x120 ■ 83



IOKP300C Oak NATURAL / 20x120 ■ 83

IOKP320C Oak NATURAL / Grip R11 / 20x120 ■ 83

Red

IOKP510CC Oak RED / 30x120 ■ 83



IOKP500C Oak RED / 20x120 ■ 83

30X120
20X120

Dark

IOKP410CC Oak DARK / 30x120 ■ 83



IOKP400C Oak DARK / 20x120 ■ 83

White

IOKP110CC Oak WHITE / 30x120 ■ 83



IOKP100C Oak WHITE / 20x120 ■ 83

Consigli di posa / Conseils de pose / Verlegeempfehlungen

Installation advise

NO 50%

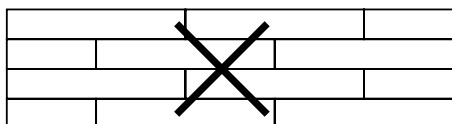

Mix solution: 30x120 / 20x120

OK

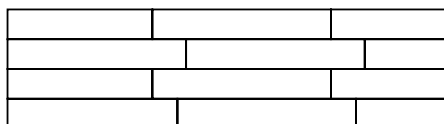

Mix solution: 30x120 (60%) / 20x120 (40%)

Pezzi Speciali
[Special items]

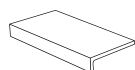

■ 121

Gradino Costa Retta
30x120 / 12"x48"



■ 129

Angolare Dx / SX
30x120 / 12"x48"



■ 24

Battiscopa
6,5x120
pcs/box 8
Kg 15

IOKB201 White
IOKB202 Blonde
IOKB203 Natural
IOKB204 Red
IOKB205 Dark

20x90

Oak

Gres Porcellanato / Porcelain stoneware / Grès cérame / Feinsteinzeug



NATURALE

Blonde



20x90 BLONDE
IOKP02 / NAT / R9 █ 65
IOKP08 / GRIP / R11 █ 65

Natural



20x90 NATURAL
IOKP03 / NAT / R9 █ 65
IOKP06 / GRIP / R11 █ 65

Red



20x90 RED
IOKP04 / NAT / R9 █ 65

White



20x90 WHITE
IOKP01 / NAT / R9 █ 65

Dark



20x90 DARK
IOKP05 / NAT / R9 █ 65
IOKP07 / GRIP / R11 █ 65

Pezzi Speciali [Special items]

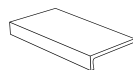

█ 116

Gradino Costa Retta
20x90

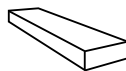

█ 121

Angolare Dx / SX
20x90



█ 9

Battiscopa
5x45
pcs/box 30

IOKB01 White
IOKB02 Blonde
IOKB03 Natural
IOKB04 Red
IOKB05 Dark

OAK

Blonde



Natural



Red



White



Dark



ONTARIO

RETTIFICATO / R9

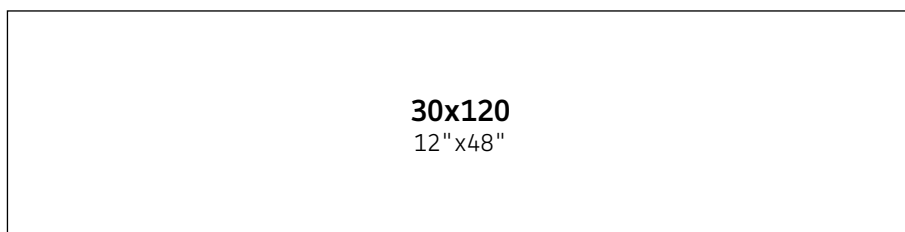

30x120
12" x 48"

▼
9,5 mm
▲

Gres Porcellanato
Porcelain stoneware
Grès cérame
Feinsteinzeug

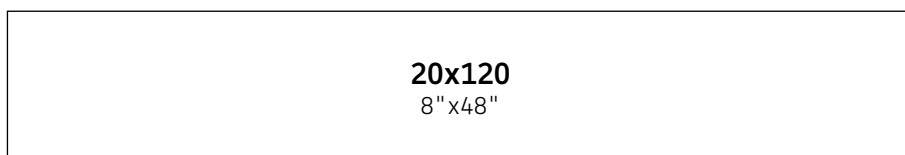

20x120
8" x 48"

▼
9,5 mm
▲

Miele

Naturale

Grigio

Bianco



FORMATO Size	SPESSORE Thickness	SCATOLE Boxes			PALETTE Pallets		
		pcs	m ²	kg	box	m ²	kg
30x120	9,5	4	1,44	28,40	36	51,84	1040
20x120	9,5	6	1,44	28,90	36	51,84	1060



Ontario



Naturale



Miele



Grigio



Bianco

Web site
More info

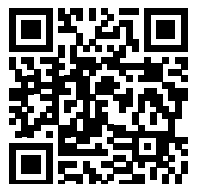





FLOOR | ONTARIO **MIELE**

30x120
20x120

Ontario

Gres Porcellanato / Porcelain stoneware / Grès cérame / Feinsteinzeug



RETTIFICATO

Naturale

IONP50CC Ontario NATURALE / 30x120 ■ 83



IONP05C Ontario NATURALE / 20x120 ■ 83

Miele

IONP30CC Ontario MIELE / 30x120 ■ 83



IONP03C Ontario MIELE / 20x120 ■ 83

Skirting ■ 24
6,5x120



8 pz
15 Kg.



IONB05 BATT. Ontario NATURALE



IONB03 BATT. Ontario MIELE

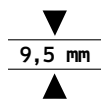

RETTIFICATO

30X120

20X120

Grigio

IONP40CC Ontario GRIGIO / 30x120 ■ 83



IONP04C Ontario GRIGIO / 20x120 ■ 83

Bianco

IONP10CC Ontario BIANCO / 30x120 ■ 83



IONP01C Ontario BIANCO / 20x120 ■ 83



IONB01 BATT. Ontario BIANCO



IONB04 BATT. Ontario GRIGIO

Vendita solo a scatole complete. To be sold as full box only.
Vendable uniquement en boîtes entières. Abnahme nur volle pakete.

Ontario

Gres Porcellanato / Porcelain stoneware / Grès cérame / Feinsteinzeug

Special pieces

Pezzi speciali

30x120 / 12"x 48"

Gradino costa retta ■ 121

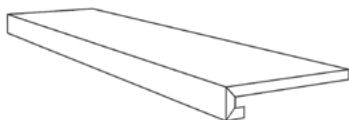

Angolare DX e SX ■ 129

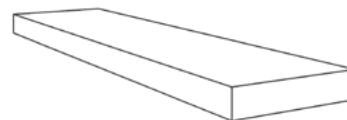

Consigli di posa / Conseils de pose / Verlegeempfehlungen

Installation advise



NO 50%

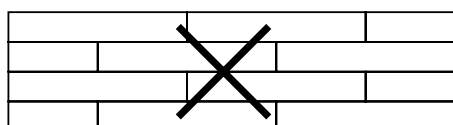

Mix solution: 30x120 / 20x120

OK

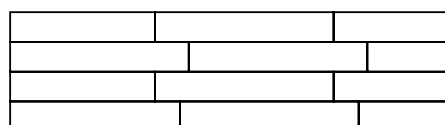

Mix solution: 30x120 (60%) / 20x120 (40%)

ONTARIO



Web site
More info



BAITA

Gres Porcellanato
Porcelain stoneware
Grès cérame
Feinsteinzeug

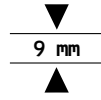

20x90
8"x35.5"

NATURALE / R9 + R11

Morzine

Mageve

Zermat

La Villa



FORMATO Size	SPESSORE Thickness	SCATOLE Boxes			PALETTE Pallets		
		pcs	m ²	kg	box	m ²	kg
20x90 NAT	9	6	1,10	19.60	60	66,00	1195
20x90 GRIP	9	6	1,10	19.60	60	66,00	1195



Baita



La Villa



Morzine



Mageve



Zermat





FLOOR | BAITA **LA VILLA**

20x90

Baita

Gres Porcellanato / Porcelain stoneware / Grès cérame / Feinsteinzeug

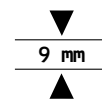

NATURALE

La Villa



20x90 LA VILLA
IBAP01 / NAT / R9 ■ 65

Morzine



20x90 MORZINE
IBAP03 / NAT / R9 ■ 65

Megeve



20x90 MEGEVE
IBAP02 / NAT / R9 ■ 65
IBAP06 / GRIP / R11 ■ 65

Zermat



20x90 ZERMAT
IBAP04 / NAT / R9 ■ 65
IBAP05 / GRIP / R11 ■ 65

Pezzi Speciali [Special items]

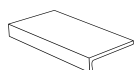

■ 116

Gradino Costa Retta
20x90

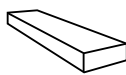

■ 121

Angolare Dx / SX
20x90



■ 11

Battiscopa
8x45
pcs/box 18
Kg 11

IBAB01 La Villa
IBAB02 Megeve
IBAB03 Morzine
IBAB04 Zermat

BAITA



Consigli di posa / Conseils de pose / Verlegeempfehlungen

NO 50%

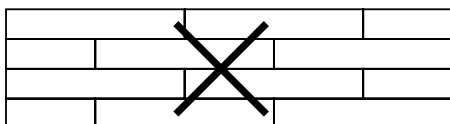

Installation advise

OK

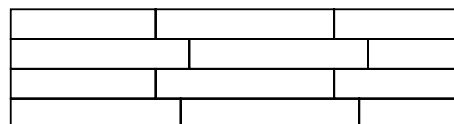

idea
ceramica

PAVIMENTO | FLOOR





PAVIMENTO | FLOOR



Web site
More info

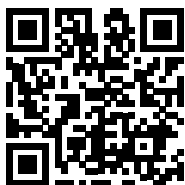

URBAN STONE

RETTIFICATO / R10

Gres Porcellanato
Porcelain stoneware
Grès cérame
Feinsteinzeug

60x60
24"x24"

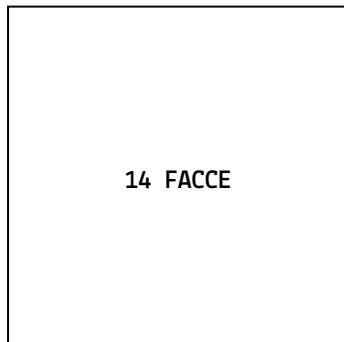

60x120
24"x47"

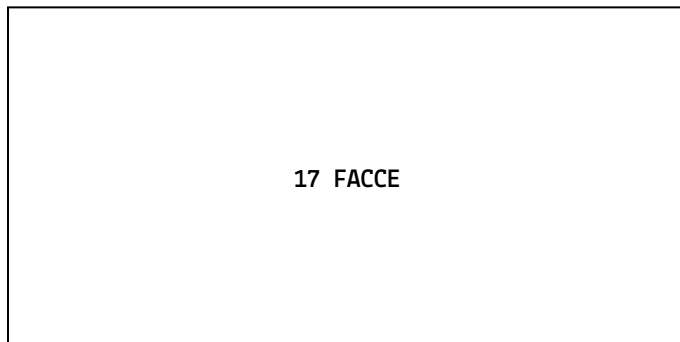

80x80
32"x32"

60x60
24"x24"

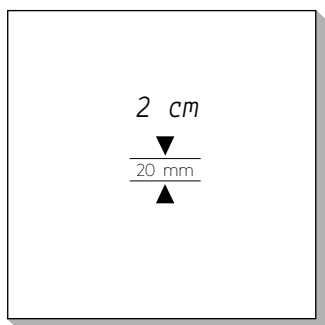

RET / R11 / A+B+C

30x60
12"x24"

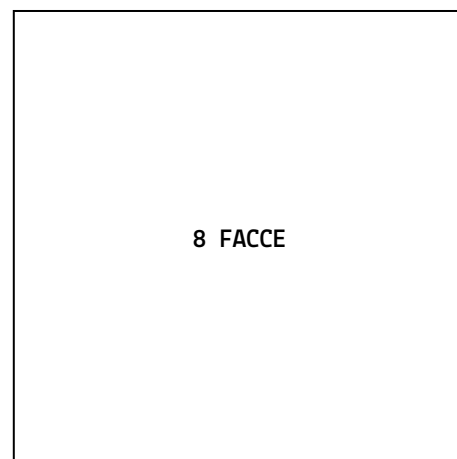
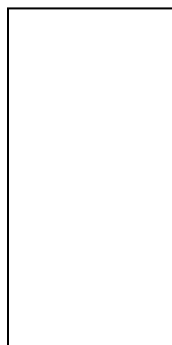

FORMATO Size	SPESSORE Thickness	SCATOLE Boxes			PALETTE Pallets		
		pcs	m ²	kg	box	m ²	kg
80x80	9,5	2	1,28	28,16	40	51,20	1144
60x120	9,5	2	1,44	29,70	36	51,84	1087
60x60	9,5	4	1,44	27,20	30	43,20	834
30x60	9,5	7	1,26	24,00	40	50,40	978
60x60 2CM	20	2	0,72	33,00	32	23,04	1074



Urban Stone



Ice

Greyge

Almond

Dark

MATCHING WALL TILES | Pag. 170

Decori **Urban Stone**

TRAMONTO

ALBA

MONDRIAN

RETRO'

SALICE VERDE

SALICE BLU

AMAZZONIA

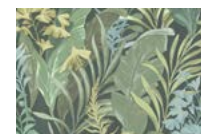
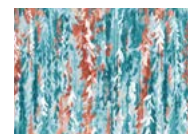
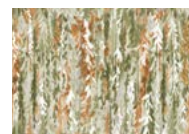



FLOOR | URBAN STONE **ICE** | 60x120



FLOOR | URBAN STONE **GREYGE** | 60x120



FLOOR | URBAN STONE **GREYGE** | 80x80



URBAN STONE | 60x120

RET / R10 / A+B $\frac{9,5 \text{ mm}}{\triangle}$

ICE



60X120 U.STONE ICE
ISTP01 / RET

GREYGE



■ 74 60X120 U.STONE GREYGE
ISTP02 / RET

ALMOND



■ 74 60X120 U.STONE ALMOND
ISTP03 / RET

DARK



■ 74 60X120 U.STONE DARK
ISTP04 / RET

URBAN STONE | 60x60

ICE

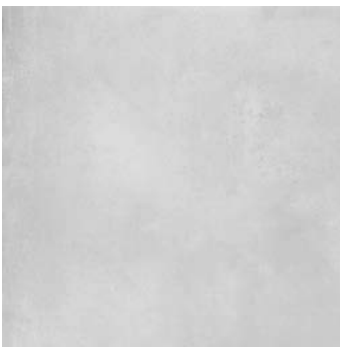

60X60 U.STONE ICE
ISTP05 / RET

GREYGE



■ 64 60X60 U.STONE GREYGE
ISTP06 / RET

ALMOND



■ 64 60X60 U.STONE ALMOND
ISTP07 / RET

DARK



■ 64 60X60 U.STONE DARK
ISTP08 / RET

URBAN STONE | 30x60

ICE



30X60 U.STONE ICE
ISTP15 / RET

GREYGE

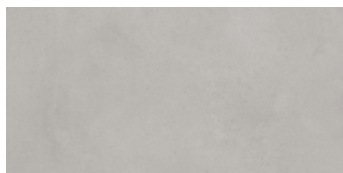

■ 64 30X60 U.STONE GREYGE
ISTP16 / RET

ALMOND



■ 64 30X60 U.STONE ALMOND
ISTP17 / RET

DARK

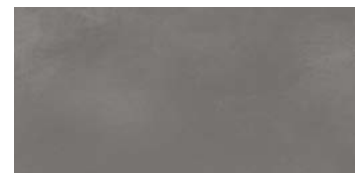

■ 64 30X60 U.STONE DARK
ISTP18 / RET

URBAN STONE | 80x80

RET / R10 / A+B $\frac{9,5 \text{ mm}}{\triangle}$

ICE



80X80 U.STONE ICE
ISTP09 / RET

DARK



■ 74 80X80 U.STONE DARK
ISTP12 / RET ■ 74

GREYGE



80X80 U.STONE GREYGE
ISTP10 / RET
ISTP13 / RET / GRIP R11

ALMOND



■ 74 80X80 U.STONE ALMOND
ISTP11 / RET
ISTP14 / RET / GRIP R11 ■ 74
GRIP **GRIP**

URBAN STONE | 60x60 2CM

RET / R11 $\frac{20 \text{ mm}}{\triangle}$
A + B + C

GREYGE

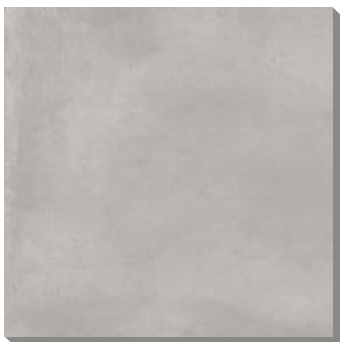

60X60 U.STONE GREYGE ■ 91
ISTP21 / RET / GRIP R11

ALMOND



60X60 U.STONE ALMOND ■ 91
ISTP20 / RET / GRIP R11

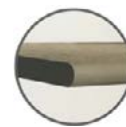

TORO 180°

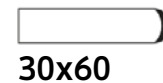

30x60

ISTT21 U.STONE GREYGE / GRIP TORO 180°
ISTT16 U.STONE ALMOND / GRIP TORO 180°





GREYGE



ICE



ALMOND



DARK

URBAN STONE

DETAIL | DETTAGLIO



Battiscopa / 8x60

15 pz  13



ISTB05 Batt. U.Stone ICE
ISTB06 Batt. U.Stone GREYGE
ISTB07 Batt. U.Stone ALMOND
ISTB08 Batt. U.Stone DARK

 39 Esagono /30x34



 su rete
(Mesh mounted)

 6 pz

ISTM05 Esag.T.12 U.Stone ICE
ISTM06 Esag.T.12 U.Stone GREYGE
ISTM07 Esag.T.12 U.Stone ALMOND
ISTM08 Esag.T.12 U.Stone DARK

Web site
More info



DECORI **URBAN STONE**

Gres Porcellanato
Porcelain stoneware
Grès cérame
Feinsteinzeug

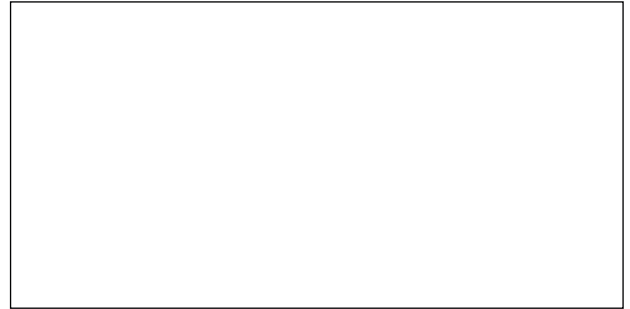

RETTIFICATO / R10

▼
9,5 mm
▲



60x120
24"x48"



FORMATO Size	SPESSORE Thickness	SCATOLE Boxes			PALETTE Pallets		
cm	mm	pcs	m ²	kg	box	m ²	kg
60x120	9,5	2	1,44	29,70	36	51,84	1087



Decori **Urban Stone**

TRAMONTO



ALBA



MONDRIAN



RETRO'



SALICE VERDE



SALICE BLU

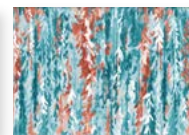

AMAZZONIA



MATCHING FLOOR | Pag. 160

Urban Stone



Ice

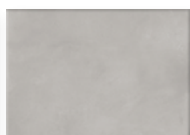

Greyge



Almond

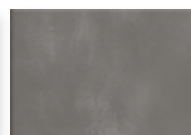

Dark



WALL TILE | **TRAMONTO** | 60x120



WALL TILE | **ALBA** | 60x120



WALL TILE | **MONDRIAN** | 60x120





WALL TILE | **RETRO** | 60x120

URBAN STONE DECORI | 60x120

TRAMONTO



60X120 DEC. TRAMONTO
ISTD01 / RET

■ 90

ALBA



60X120 DEC. ALBA
ISTD02 / RET

■ 90

Wall & Floor

MONDRIAN



60X120 DEC. **MONDRIAN**
ISTD03 / RET

■ 90

RETRO'



60X120 DEC. **RETRO'**
ISTD04 / RET

■ 90



WALL TILE | **SALICE BLU** | 60x120

FLOOR TILE | **URBAN STONE** | ICE



WALL TILE | **SALICE VERDE** | 60x120

FLOOR TILE | **URBAN STONE** | ICE

SALICE BLU

60x120

SALICE VERDE

A



B



60X120 DEC. SALICE BLU A+B
ISTD06 / RET

136 
2 pz
[A+B]



60X120 DEC. SALICE VERDE A+B
ISTD05 / RET

136 
2 pz
[A+B]

Cod. *NB: prezzo per scatola completa.
*NB: price per full box.





AMAZZONIA | 60x120



B

A

60X120 DEC. **AMAZZONIA** COMPO **A + B**
 ISTD07 / RET

136



 2 pz
 [A+B]

Cod. *NB: prezzo per scatola completa.
 *NB: price per full box.

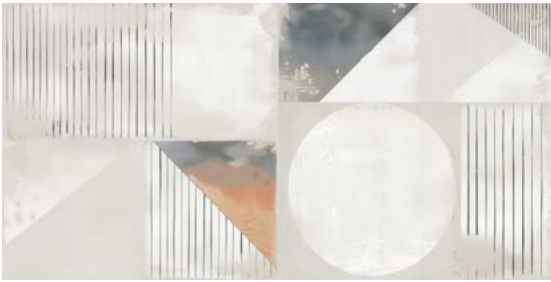

URBAN STONE DECORI | 60x120 Wall & Floor

MONDRIAN



MONDRIAN

RETRO'



RETRO'

TRAMONTO



ALBA

SALICE BLU



SALICE VERDE

AMAZZONIA



AMAZZONIA

DECORI **URBAN STONE**

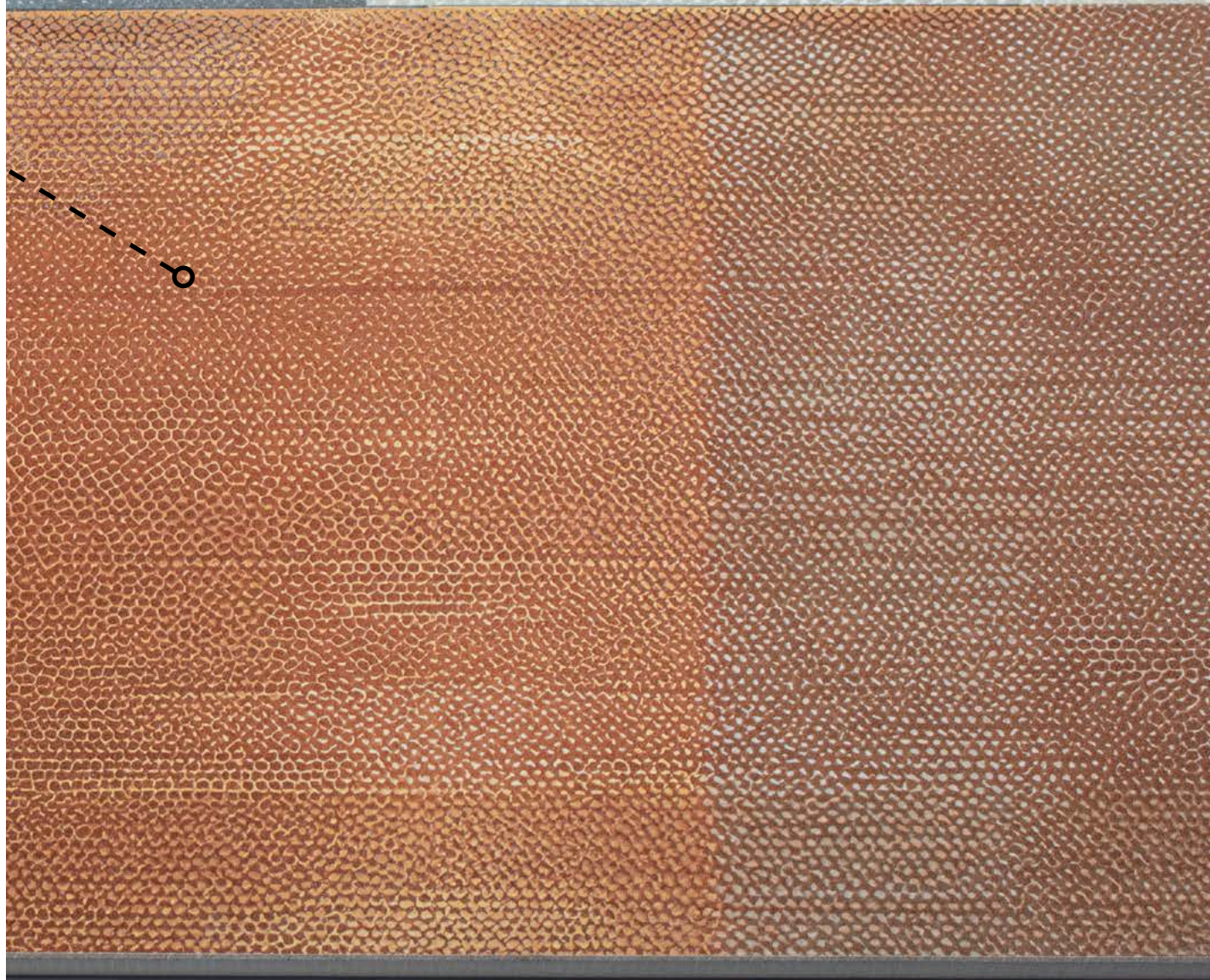

RETRO'

RESINA'

Gres Porcellanato
Porcelain stoneware
Grès cérame
Feinsteinzeug

RETTIFICATO / R9

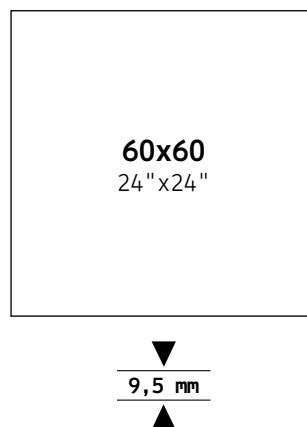
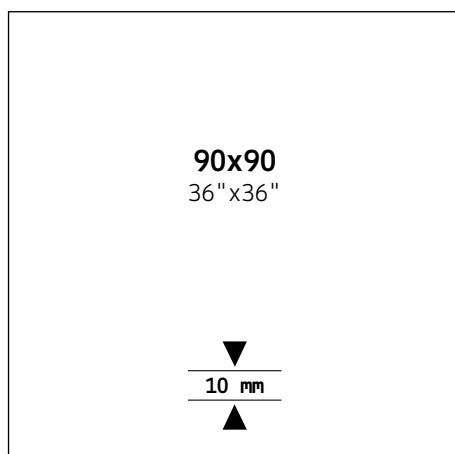
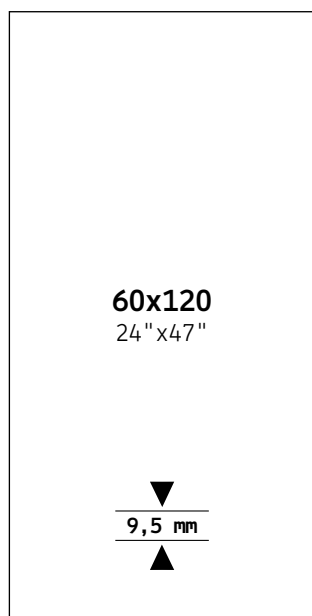

DETAIL | DETTAGLIO



FORMATO Size	SPESSORE Thickness	SCATOLE Boxes			PALETTE Pallets		
		pcs	m ²	kg	box	m ²	kg
90x90	10	2	1,62	36,30	21	34,02	780
60x120	9,5	2	1,44	29,70	36	51,84	1087
60x60	9,5	4	1,44	27,20	30	43,20	834
DECORI 60x120	9,5	2	1,44	29,70	36	51,84	1087





Resina'

Ghiaccio



Almond



Taupe



Grigio



MATCHING WALL TILES

Decori Resina'



Forest Mix



Triangle Gold Mix



Jungle Bianco Mix



Jungle Avio Mix

Web site
More info

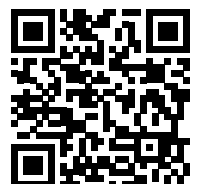



FLOOR | RESINA **ALMOND** | 60x120



FLOOR | RESINA **GHIACCIO** | 60x60

RESINÀ | 60x120

RET / R9 $\frac{9,5\text{ mm}}{\triangle}$

GHIACCIO



60x120 GHIACCIO
IRSR13C / RET / R9

■ 74

ALMOND



60x120 ALMOND
IRSR14C / RET / R9

■ 74

TAUPE



60x120 TAUPE
IRSR15C / RET / R9

■ 74

GRIGIO



60x120 GRIGIO
IRSR16C / RET / R9

■ 74

RESINÀ | 60x60

GHIACCIO



60x60 GHIACCIO
IRSR05 / RET / R9

■ 64

ALMOND



60x60 ALMOND
IRSR06 / RET / R9

■ 64

TAUPE



60x60 TAUPE
IRSR07 / RET / R9

■ 64

GRIGIO



60x60 GRIGIO
IRSR08 / RET / R9

■ 64

MOSAICO | 30x30

 su rete
(Mesh mounted)

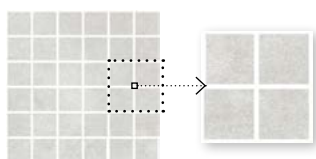

5x5 MOS. RESINA GHIACCIO
IRSM01 / RET / R9 ■ 21

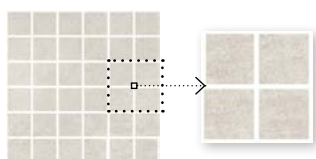

5x5 MOS. RESINA ALMOND
IRSM02 / RET / R9 ■ 21

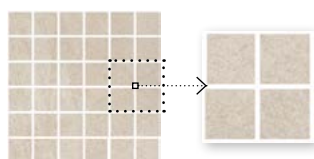

5x5 MOS. RESINA TAUPE
IRSM04 / RET / R9 ■ 21

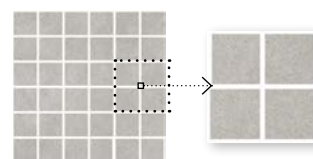

5x5 MOS. RESINA GRIGIO
IRSM03 / RET / R9 ■ 21



9 pz

GHIACCIO

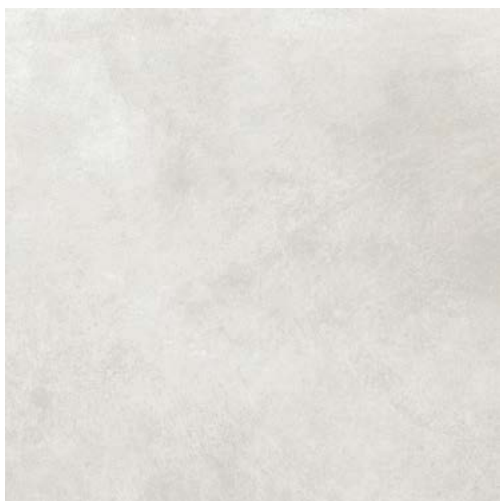

90x90 GHIACCIO
IRSR21 / RET / R9

■ 74

ALMOND



90x90 ALMOND
IRSR22 / RET / R9

■ 74

GRIGIO



90x90 GRIGIO
IRSR24 / RET / R9

■ 74

TAUPE



90x90 TAUPE
IRSR23 / RET / R9

■ 74

Pezzi Speciali
[Special items]



■ 13

Battiscopa
8x60
pcs/box 15

IRSB01 Ghiaccio
IRSB02 Almond
IRSB03 Taupe
IRSB04 Grigio



WALL TILE | **TRIANGLE GOLD MIX** | 60x120





WALL TILE | **JUNGLE BIANCO MIX** | 60x120



WALL TILE | **JUNGLE AVIO MIX** | 60x120

DECORI RESINA | 60x120

Gres Porcellanato / Porcelain stoneware / Grès cérame / Feinsteinzeug



RETTIFICATO

FOREST MIX



60x120 FOREST MIX
IRSD01C / RET / R9

■ 90



2 pz x Box
RANDOM

TRIANGLE GOLD MIX



60x120 TRIANGLE GOLD MIX
IRSD02C / RET / R9

■ 90



2 pz x Box
RANDOM

DECORI RESINA | 60x120

Gres Porcellanato / Porcelain stoneware / Grès cérame / Feinsteinzeug



RETTIFICATO

JUNGLE BIANCO MIX



60x120 JUNGLE BIANCO MIX
IRSD03C / RET / R9

■ 90



2 pz x Box
RANDOM

JUNGLE AVIO MIX



60x120 JUNGLE AVIO MIX
IRSD04C / RET / R9

■ 90



2 pz x Box
RANDOM

Floor RESINA

DETAIL | DETTAGLIO



ALMOND

TAUPE

GRIGIO

GHIACCIO

DEC RESINA

JUNGLE AVIO

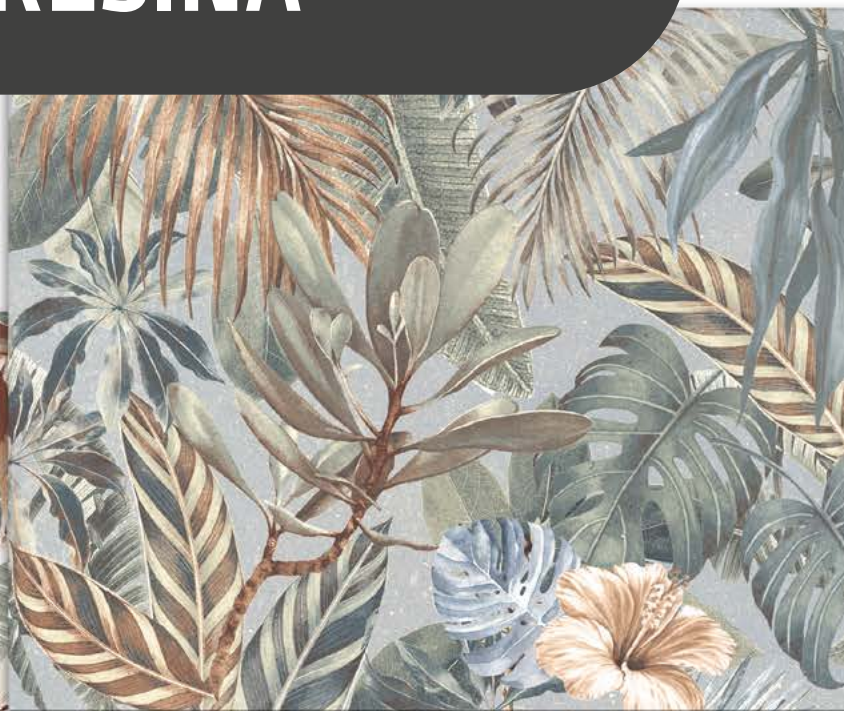

JUNGLE BIANCO



FOREST MIX



TRIANGLE GOLD

Web site
More info



CITY LIFE

Gres Porcellanato
Porcelain stoneware
Grès cérame
Feinsteinzeug

RETTIFICATO / R10

▼
9,5 mm
▲

60x60
24" x 24"

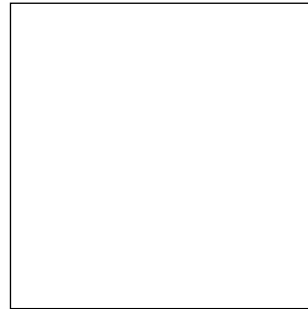

60x120
24" x 47"

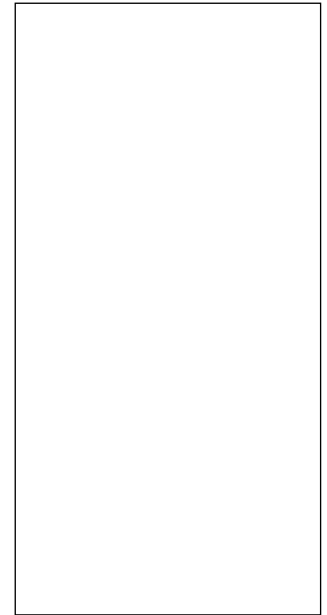

30x60
12" x 24"



▼
9,5 mm
▲



FORMATO Size	SPESSORE Thickness	SCATOLE Boxes			PALETTE Pallets		
		pcs	m ²	kg	box	m ²	kg
60x120	9,5	2	1,44	29,70	36	51,84	1087
60x60	9,5	4	1,44	27,20	30	43,20	834
30x60	9,5	7	1,26	24	40	50,40	978



FLOOR | CITY LIFE **LONDON** | 60x120

City Life

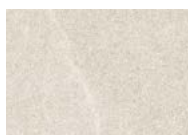

Madrid



Paris

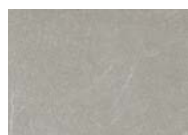

Milan



London



FLOOR | CITY LIFE **MILAN** | 60x120



FLOOR | CITY LIFE **PARIS** | 60x60



FLOOR | CITY LIFE **MADRID** | 30x60

CITY LIFE | 60x120

RET / R10



MADRID



60X120 C.LIFE MADRID
ICLP11 / RET

■ 75

PARIS



60X120 C.LIFE PARIS
ICLP04 / RET

■ 75

MILAN



60X120 C.LIFE MILAN
ICLP05 / RET

■ 75

LONDON



60X120 C.LIFE LONDON
ICLP06 / RET

■ 75

CITY LIFE | 60x60

MADRID



60X60 C.LIFE MADRID
ICLP12 / RET

■ 64

PARIS



60X60 C.LIFE PARIS
ICLP07 / RET

■ 64

MILAN



60X60 C.LIFE MILAN
ICLP08 / RET

■ 64

LONDON



60X60 C.LIFE LONDON
ICLP09 / RET

■ 64

CITY LIFE | 30x60 GRIP

RET / R11



MADRID

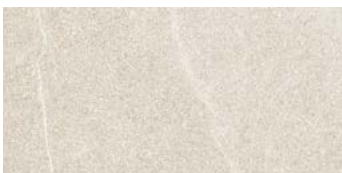

30X60 C.LIFE MADRID
ICLP10 / RET / R11 GRIP

■ 64

PARIS



30X60 C.LIFE PARIS
ICLP01 / RET / R11 GRIP

■ 64

MILAN



30X60 C.LIFE MILAN
ICLP02 / RET / R11 GRIP

■ 64

LONDON



30X60 C.LIFE LONDON
ICLP03 / RET / R11 GRIP

■ 64



PARIS

MILAN

LONDON

MADRID

CITY LIFE

DETAIL | DETTAGLIO

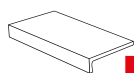

Elle Monolitico
15x30x4
pcs/box 8

■ 28

ICLP13 PARIS
ICLP14 MILAN
ICLP15 LONDON
ICLP16 MADRID

Battiscopa / 8x60

15 pz
■ 13



ICLB01 Batt. C.Life PARIS
ICLB02 Batt. C.Life MILAN
ICLB03 Batt. C.Life LONDON
ICLB04 Batt. C.Life MADRID

LIMESTONE

Gres Porcellanato
Porcelain stoneware
Grès cérame
Feinsteinzeug

RETTIFICATO
R10 A+B

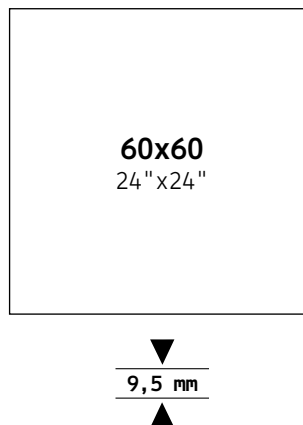
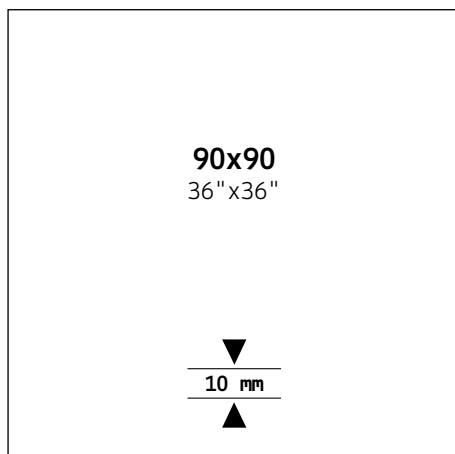
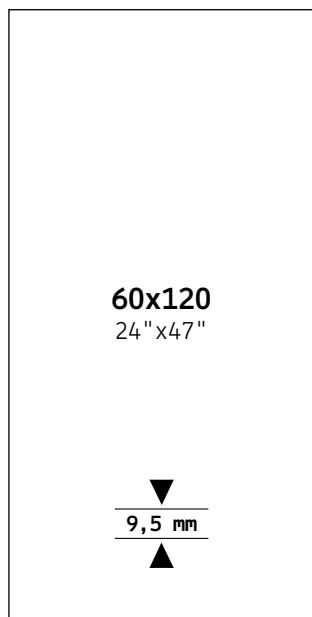

FORMATO Size	SPESSORE Thickness	SCATOLE Boxes			PALETTE Pallets		
		pcs	m ²	kg	box	m ²	kg
90x90	10	2	1,62	36,30	21	34,02	780
60x120	9,5	2	1,44	29,70	36	51,84	1087
60x60	9,5	4	1,44	27,20	30	43,20	834
STRUTT 60x120	9,5	2	1,44	29,70	36	51,84	1087



LIMESTONE

FLOOR | LIMESTONE **TAUPE** | 60x120



FLOOR | LIMESTONE **WHITE** | 90x90



WALL | STRUTT. **TAUPE** | 60x120
FLOOR | LIMESTONE **TAUPE** | 60x60



WALL | STRUTT. **WHITE** | 60x120

FLOOR | LIMESTONE **GREY** | 90x90

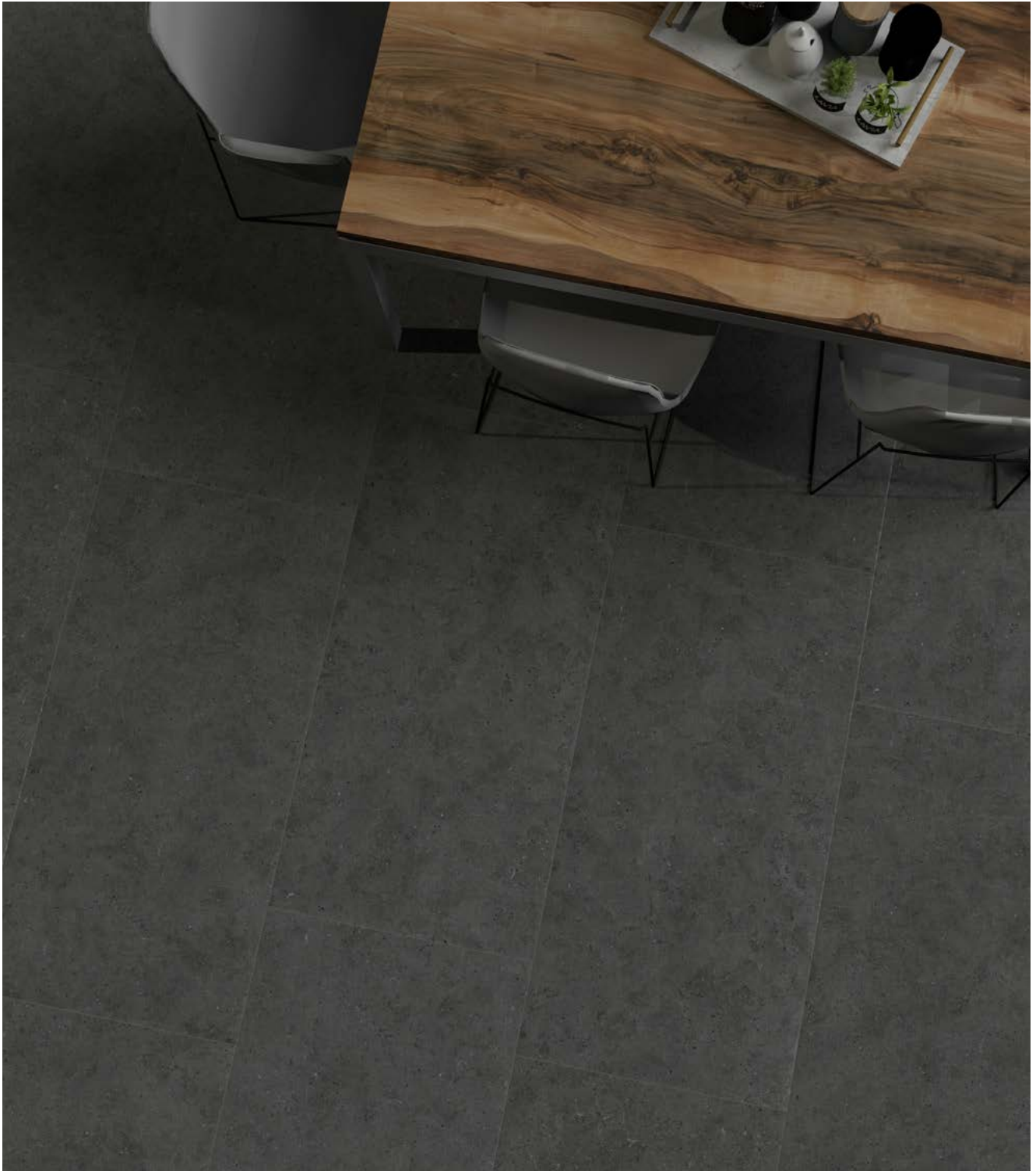

FLOOR | LIMESTONE **ANTHRACITE** | 60x120

LIMESTONE

60x60

90x90 | 60x120 | 60x60

Gres Porcellanato / Porcelain stoneware
Grès cérame / Feinsteinzeug

RETTIFICATO
R10 A+B

▼
9,5 mm
▲



MLIP11 LIMESTONE WHITE |RET|



MLIP12 LIMESTONE BEIGE |RET|



MLIP13 LIMESTONE GREY |RET|



MLIP14 LIMESTONE TAUPE |RET|



MLIP15 LIMESTONE ANTHRACITE |RET|

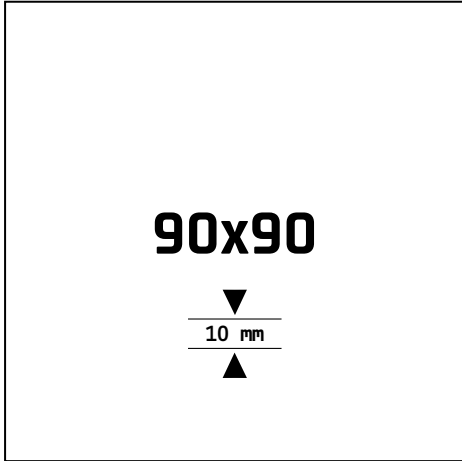

90x90

▼
10 mm
▲



MLIP01 LIMESTONE WHITE |RET|



MLIP02 LIMESTONE BEIGE |RET|



MLIP03 LIMESTONE GREY |RET|



MLIP04 LIMESTONE TAUPE |RET|



MLIP05 LIMESTONE ANTHRACITE |RET|

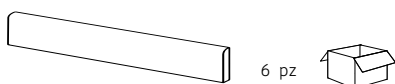

Battiscopa / 7,2x90 ■ 21

MLIB01 Batt. Limestone WHITE | 90cm
MLIB02 Batt. Limestone BEIGE | 90cm
MLIB03 Batt. Limestone GREY | 90cm
MLIB04 Batt. Limestone TAUPE | 90cm
MLIB05 Batt. Limestone ANTHRACITE | 90cm

60x120

Strutturato

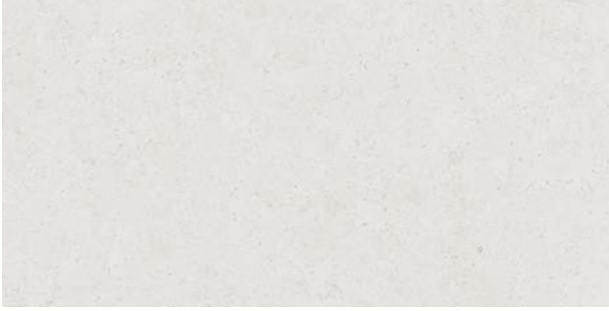

MLIP06 LIMESTONE WHITE |RET| 60X120



MLIP16 LIMESTONE WHITE STRUTT. |RET| 60X120



MLIP07 LIMESTONE BEIGE |RET| 60X120



MLIP17 LIMESTONE BEIGE STRUTT. |RET| 60X120



MLIP08 LIMESTONE GREY |RET| 60X120



MLIP18 LIMESTONE GREY STRUTT. |RET| 60X120



MLIP09 LIMESTONE TAUPE |RET| 60X120



MLIP19 LIMESTONE TAUPE STRUTT. |RET| 60X120



MLIP10 LIMESTONE ANTHRACITE |RET| 60X120



MLIP20 LIMESTONE ANTHRACITE STRUTT. |RET| 60X120



15 pz



Battiscopa / 7,2x60 ■ 13

MLIB06 Batt. Limestone WHITE | 60cm
MLIB07 Batt. Limestone BEIGE | 60cm
MLIB08 Batt. Limestone GREY | 60cm
MLIB09 Batt. Limestone TAUPE | 60cm
MLIB10 Batt. Limestone ANTHRACITE | 60cm





NAT R9
GRIP R11 / A+B+C

DEA

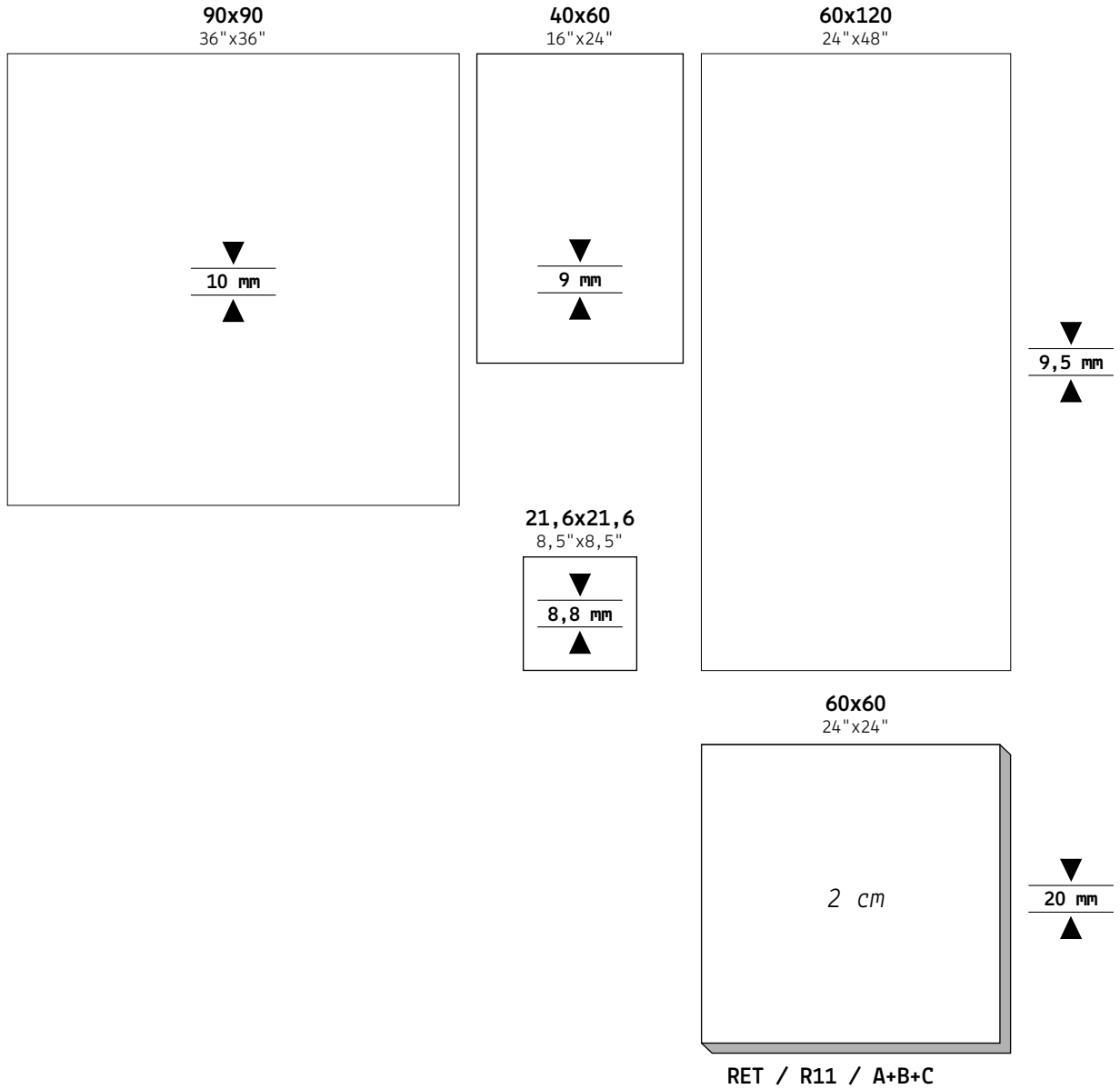
Gres PorcellaRETo
Porcelain stoneware
Grès cérame
Feinsteinzeug



FORMATO Size	SPESSORE Thickness	SCATOLE Boxes 			PALETTE Pallets 		
		pcs	m ²	kg	box	m ²	kg
60x120	9,5	2	1,44	29,70	36	51,84	1087
90x90	10	2	1,62	35,80	21	34,02	780
40x60	9	5	1,20	22,00	48	57,60	1074
21,6x21,6	8,8	28	1,31	24,50	60	78,60	1488
2 CM	20	2	0,72	33,00	32	23,04	1074





Dea



Ivory

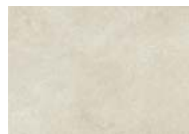

Gold



FLOOR | DEA **GOLD** + MOSAICO **DEA MIX** | 60x120

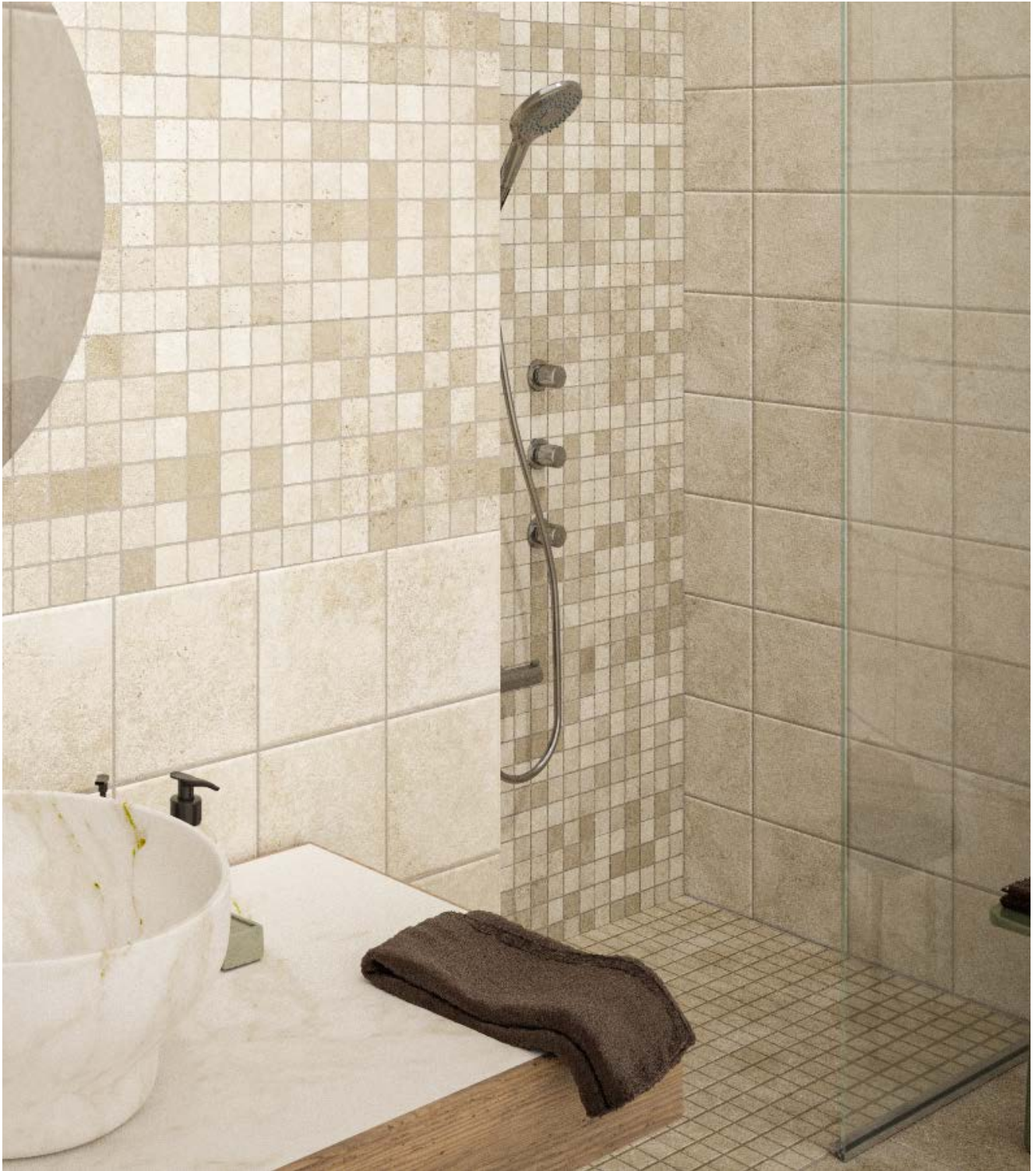

FLOOR | DEA **IVORY** + MOSAICO **DEA MIX** | 21,6x21,6

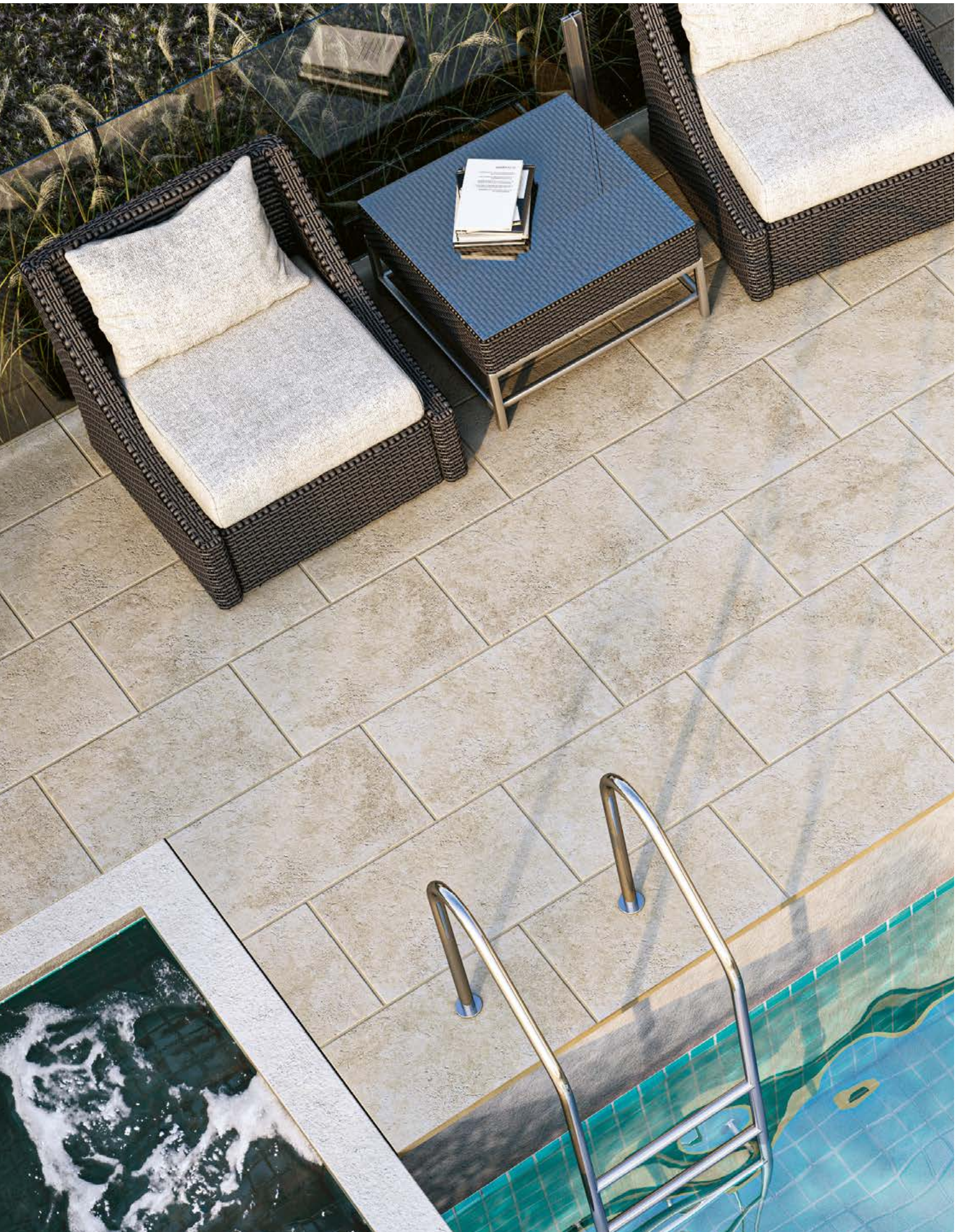

FLOOR | DEA **IVORY** | 40x60



FLOOR | DEA **IVORY** | 60x120

DEA | 60x120 RET

RET / R9 $\frac{9,5\text{ mm}}{\triangle}$
RET / R11

IVORY

GOLD



60X120 DEA IVORY
IDEP11 / RET / R9
IDEP13 / RET / R11

■ 74

60X120 DEA GOLD
IDEP12 / RET / R9
IDEP14 / RET / R11

■ 74

DEA | 40x60

MOSAICO | 30x30

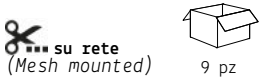

5x5 MOS. DEA IVORY
IDEM01 / GRIP / R11 ■ 21



5x5 MOS. DEA MIX
IDEM03 / NAT / R9 ■ 21



5x5 MOS. DEA GOLD
IDEM02 / GRIP / R11 ■ 21

IVORY

GOLD



$\frac{9\text{ mm}}{\triangle}$

40x60 IVORY
IDEP05 / NAT / R9 ■ 64
IDEP07 / GRIP / R11 ■ 64

40x60 GOLD
IDEP06 / NAT / R9 ■ 64
IDEP08 / GRIP / R11 ■ 64

DEA | 21,6x21,6

IVORY

GOLD

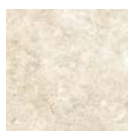
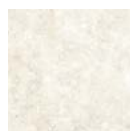

$\frac{8,8\text{ mm}}{\triangle}$

21,6x21,6 IVORY
IDEP01 / NAT / R9 ■ 64
IDEP03 / GRIP / R11 ■ 64

21,6x21,6 GOLD
IDEP02 / NAT / R9 ■ 64
IDEP04 / GRIP / R11 ■ 64

DEA | 90x90 RET

RET / R9

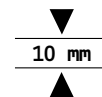

IVORY

GOLD



90x90 DEa IVORY
 IDEP15 / RET / R9
 IDEP17 / GRIP / R11

■ 74

90x90 DEa GOLD
 IDEP16 / RET / R9
 IDEP18 / GRIP / R11

■ 74

DEA | 60x60 2CM RET

RET / R11

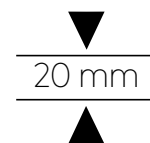

IVORY

GOLD



60x60 DEa IVORY
 MCADE05 / GRIP / R11

■ 64

60x60 DEa GOLD
 MCADE06 / GRIP / R11

■ 64



TORO 180°



30x60

IDET07 DEa IVORY / GRIP / TORO 180°
 IDET08 DEa GOLD / GRIP / TORO 180°



Elle Monolitico
 15x30x4



8pz

■ 28

IDEP09 Elle DEa IVORY
 IDEP10 Elle DEa GOLD



GOLD

DEA



IVORY

Web site
More info



MISTERY

Gres Porcellanato
Porcelain stoneware
Grès cérame
Feinsteinzeug

RETTIFICATO / R10

▼
9,5 mm
▲

60x120
24"x47"

60x60
24"x24"

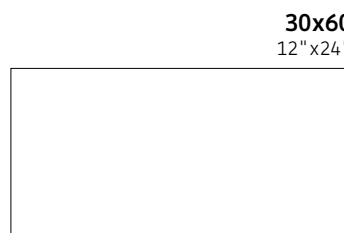
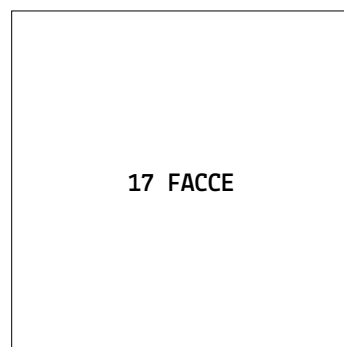
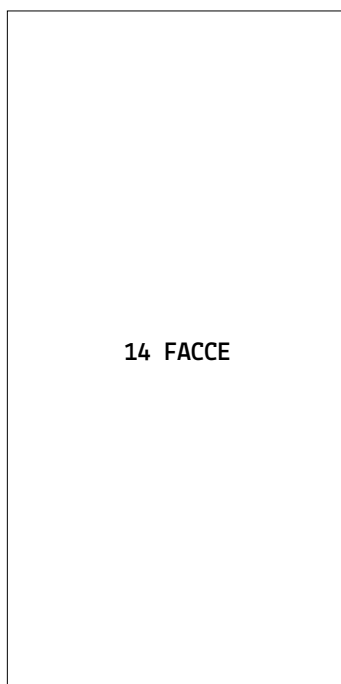

FORMATO Size	SPESSORE Thickness	SCATOLE Boxes			PALETTE Pallets		
		pcs	m ²	kg	box	m ²	kg
60x120	9,5	2	1,44	29,70	36	51,84	1087
60x60	9,5	4	1,44	27,20	30	43,20	834
30x60	9,5	7	1,26	24,00	40	50,40	978



Mistery



White

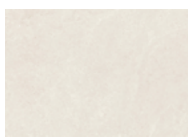

Sand

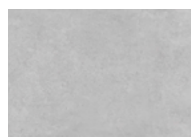

Fumè

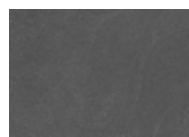

Black



FLOOR | MISTERY **FUMÈ** | 60x120



FLOOR | MISTERY **SAND** | 60x120



FUME'



WHITE

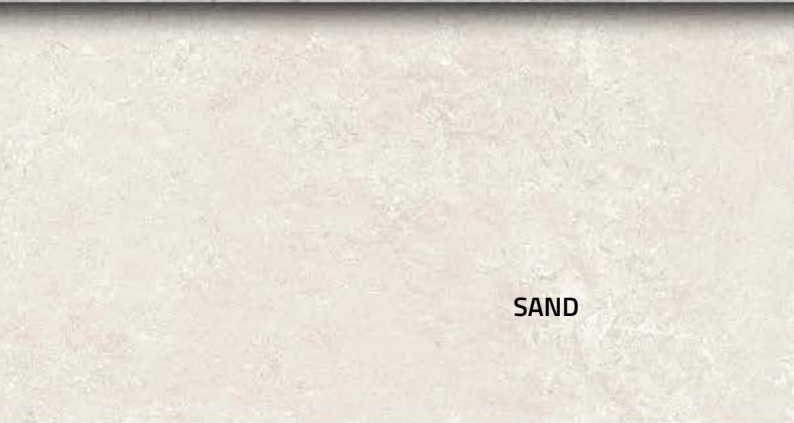

SAND



BLACK



FLOOR | MISTERY **BLACK** | 60x120

MISTERY | 60x60



FUME'



MISTERY | 30x60



BLACK



MISTERY | 60x120

RET / R10



WHITE



60X120 MISTERY WHITE
IMIP02 / RET

■ 74

SAND



60X120 MISTERY SAND
IMIP01 / RET

■ 74

FUME'

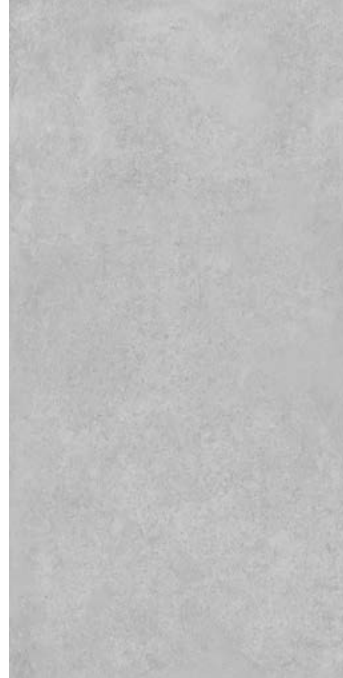

60X120 MISTERY FUME'
IMIP03 / RET

■ 74

BLACK



60X120 MISTERY BLACK
IMIP04 / RET

■ 74

MISTERY | 60x60

WHITE



60X60 MISTERY WHITE
IMIP06 / RET

■ 64

SAND



60X60 MISTERY SAND
IMIP05 / RET

■ 64

FUME'



60X60 MISTERY FUME'
IMIP07 / RET

■ 64

BLACK



60X60 MISTERY BLACK
IMIP08 / RET

■ 64

MISTERY

Gres Porcellanato / Porcelain stoneware
Grès cérame / Feinsteinzeug

MISTERY | 30x60

RET / R10 $\frac{9,5\text{mm}}$

WHITE

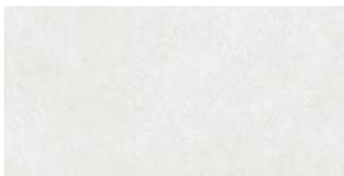

30X60 MISTERY WHITE
IMIP14 / RET

■ 64

SAND

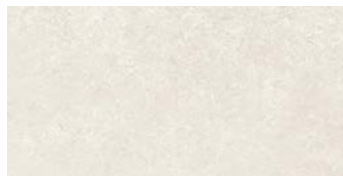

30X60 MISTERY SAND
IMIP13 / RET

■ 64

FUME'

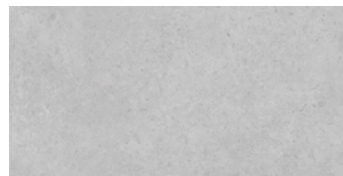

30X60 MISTERY FUME'
IMIP15 / RET

■ 64

BLACK

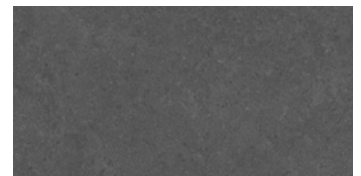

30X60 MISTERY BLACK
IMIP16 / RET

■ 64

MOSAICO | 30x30



✂ su rete
(Mesh mounted)

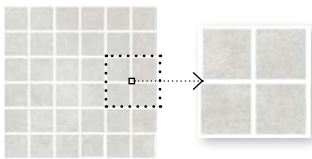

5x5 MOS. Mistery WHITE ■ 23
IMIM06 / RET / R10

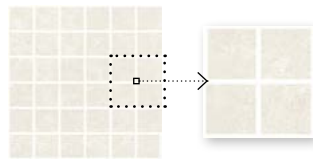

5x5 MOS. Mistery SAND ■ 23
IMIM05 / RET / R10

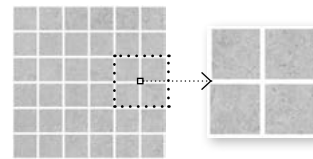

5x5 MOS. Mistery FUME' ■ 23
IMIM07 / RET / R10

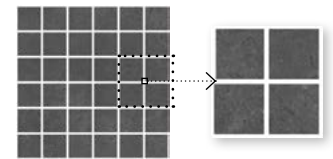

5x5 MOS. Mistery BLACK ■ 23
IMIM08 / RET / R10

Battiscopa / 8x60

15 pz



■ 13

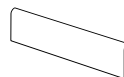

IMIB05 Batt. Mistery SAND
IMIB06 Batt. Mistery WHITE
IMIB07 Batt. Mistery FUME'
IMIB08 Batt. Mistery BLACK

Web site
More info



BLOCK

Gres Porcellanato
Porcelain stoneware
Grès cérame
Feinsteinzeug

RETTIFICATO / R9

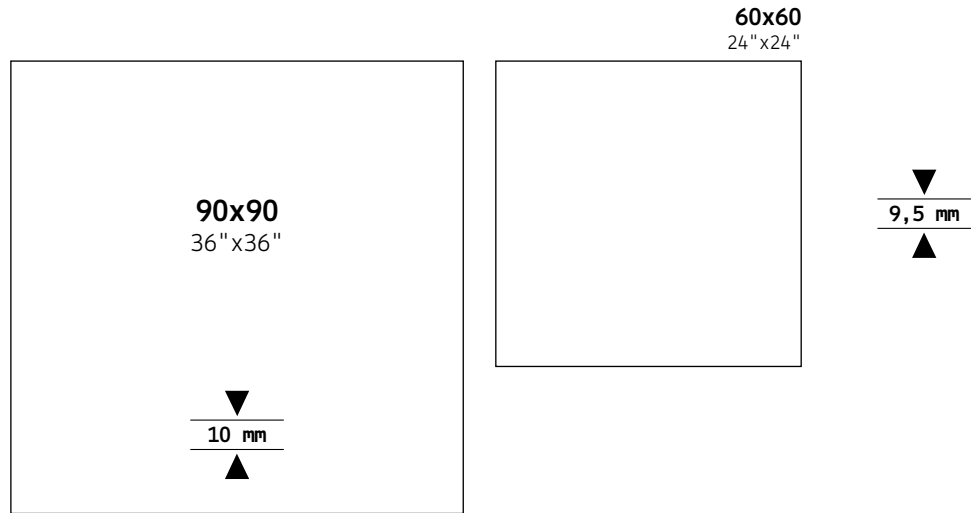

FORMATO Size	SPESSORE Thickness	SCATOLE Boxes			PALETTE Pallets		
		pcs	m ²	kg	box	m ²	kg
90x90 RET	10	2	1,62	36,30	21	34,02	780
60x60 RET	9,5	4	1,44	27,20	30	43,20	834



Block

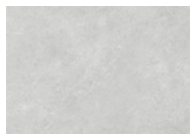

Silver



Grey

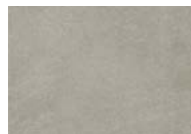

Taupe

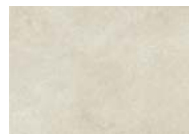

Beige



FLOOR | BLOCK **BEIGE**



FLOOR | BLOCK **GREY**

BLOCK | 90x90

RET / R9

10 mm

SILVER



90x90 SILVER
IBLP70 / RET / R9

■ 74

TAUPE



90x90 TAUPE
IBLP60 / RET / R9

■ 74

GREY



90x90 GREY
IBLP80 / RET / R9

■ 74

BEIGE



90x90 BEIGE
IBLP50 / RET / R9

■ 74

BLOCK | 60x60

RET / R9 + R11

9,5 mm

SILVER



60x60 SILVER
IBLP03CC / RET / R9
IBLP16CC / RET / GRIP R11

■ 64

GREY



60x60 GREY
IBLP04CC / RET / R9

■ 64

TAUPE



60x60 TAUPE
IBLP02CC / RET / R9

■ 64

BEIGE



60x60 BEIGE
IBLP01CC / RET / R9
IBLP15CC / RET / GRIP R11

■ 64

BLOCK



FLOOR | BLOCK **SILVER**

Pezzi Speciali
[Special items]

Skirting
Battiscopa



13

Battiscopa
8x60
pcs/box 15

IBLB01 BEIGE
IBLB02 TAUPE
IBLB03 SILVER
IBLB04 GREY

LUCANIA

Gres Porcellanato
Porcelain stoneware
Grès cérame
Feinsteinzeug

60x60
24"x24"

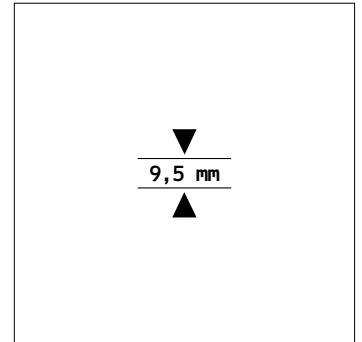

GRIP R11 / A+B+C
NAT R9

FARDELLA

POLICORO





Lucania



Fardella Beige



Policoro Grigio

FORMATO Size	SPESSORE Thickness	SCATOLE Boxes			PALETTE Pallets		
cm	mm	pcs	m ²	kg	box	m ²	kg
60x60	9,5	4	1,44	27,20	30	43,20	834

LUCANIA | FARDELLA



FLOOR | LUCANIA **FARDELLA BEIGE** | 60x60

LUCANIA | POLICORO

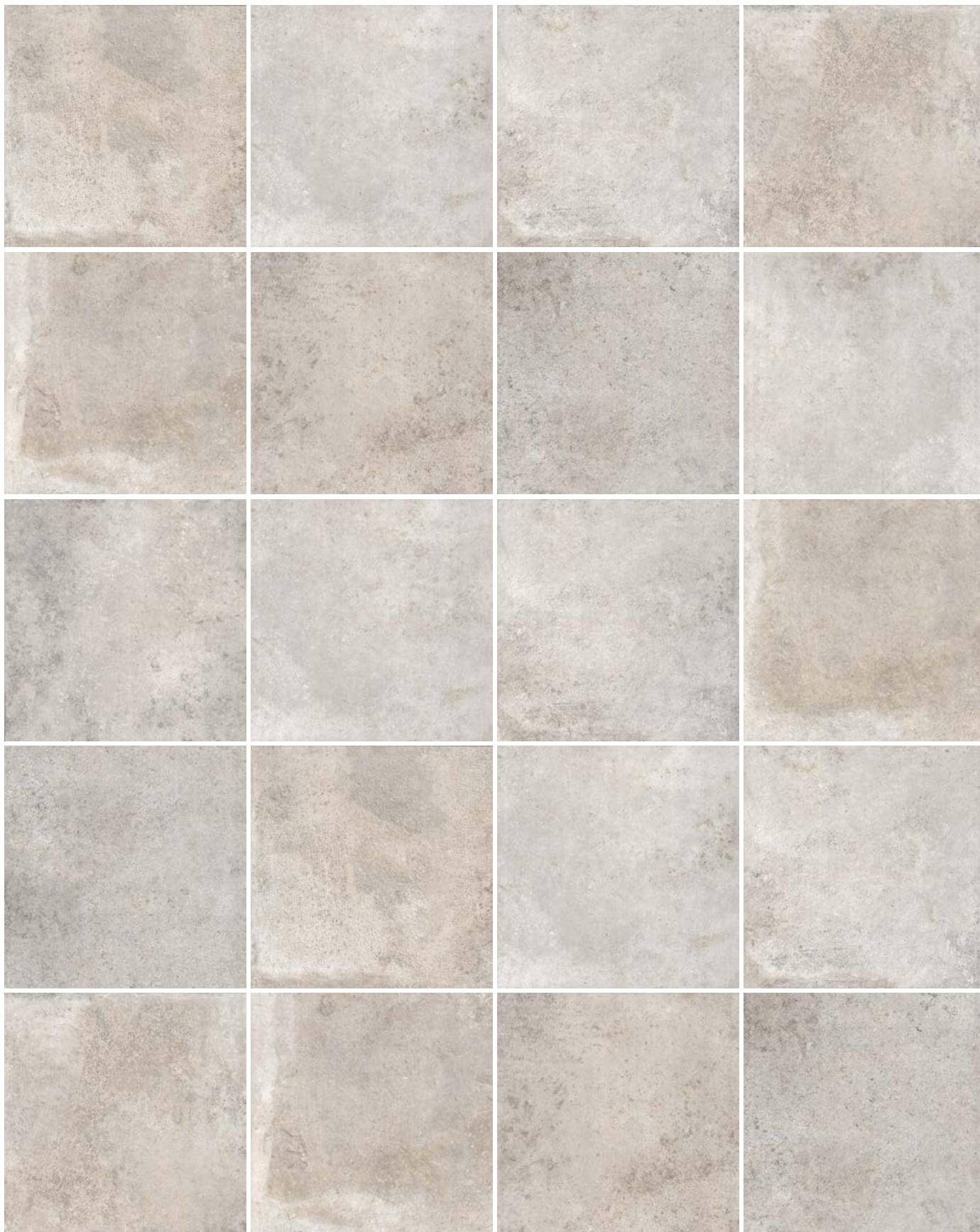

LUCANIA | 60x60

R9 + R11



INDOOR | INTERNO

R9



60x60 LUCANIA FARDELLA BEIGE
ILCP01 / NAT / R9 ■ 59



60x60 LUCANIA POLICORO GRIGIO
ILCP02 / NAT / R9 ■ 59

OUTDOOR | ESTERNO

GRIP R11



60x60 LUCANIA FARDELLA BEIGE
ILCP10 / R11 GRIP ■ 59



60x60 LUCANIA POLICORO GRIGIO
ILCP20 / R11 GRIP ■ 59

Pezzi Speciali
[Special items]

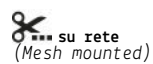

MOSAICO | 30x30

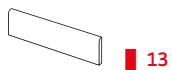

Battiscopa
8x60
pcs/box 15

ILCB01 BEIGE
ILCB02 GRIGIO



5x5 MOS. ■ 23
FARDELLA BEIGE
ILCM01
RET / R11
GRIP

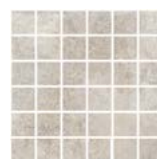

5x5 MOS. ■ 23
POLICORO GRIGIO
ILCM02
RET / R11
GRIP

LUCANIA



40x60
16"x24"

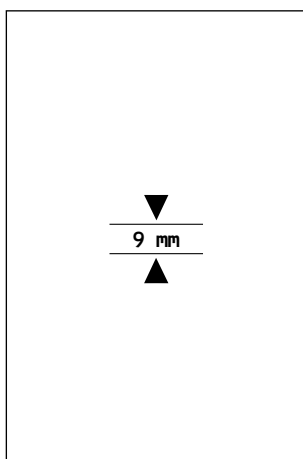

LUBERON

Gres Porcellanato
Porcelain stoneware
Grès cérame
Feinsteinzeug

GRIP R11 / A+B+C
NAT R9





Luberon



Beige



Grey

FORMATO
Size

cm

40x60

SPESSORE
Thickness

mm

9

SCATOLE
Boxes

pcs

5

m²

1,20

kg

22,00



PALETTE
Pallets

box

48

m²

57,60

kg

1074



LUBERON | 40x60

R9 + R11

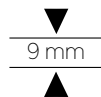

INDOOR | INTERNO

R9

BEIGE

GREY



40x60 LUBERON **BEIGE**
ILBP01 / NAT / R9

■ 64

40x60 LUBERON **GREY**
ILBP02 / NAT / R9

■ 64

OUTDOOR | ESTERNO

GRIP R11



40x60 LUBERON **BEIGE**
ILBP11 / R11 **GRIP**

■ 64

40x60 LUBERON **GREY**
ILBP12 / R11 **GRIP**

■ 64

Pezzi Speciali [Special items]



■ 13

Battiscopa
8x60
pcs/box 15

ILBB01 BEIGE
ILBB02 GREY

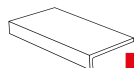

■ 28

Elle Monolitico
15x30x4
pcs/box 8

ILBP21 BEIGE
ILBP22 GREY

MOSAICO | 30x30



5x5 MOS. ■ 23
LUBERON BEIGE
ILBM01
RET / R11
GRIP



5x5 MOS. ■ 23
LUBERON GREY
ILBM02
RET / R11
GRIP

LUBERON



Web site
More info



POLINESIA

Gres Porcellanato
Porcelain stoneware
Grès cérame
Feinsteinzeug

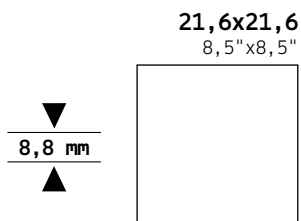

NAT R9

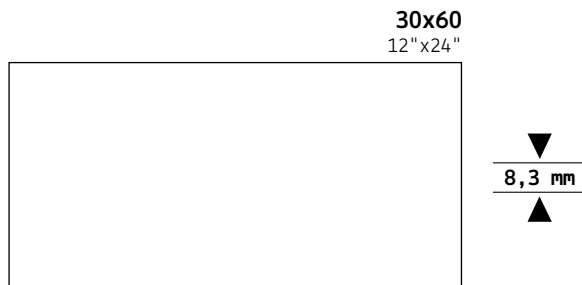

NAT R9 + GRIP R11 / A+B+C

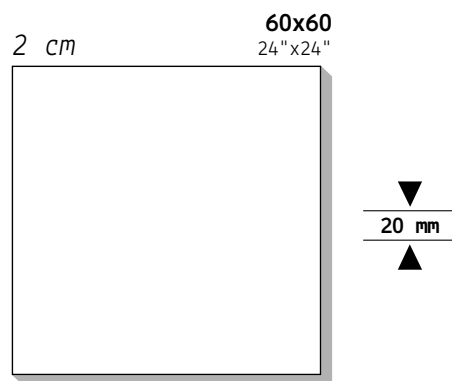

RET / R11 / A+B+C



FORMATO Size	SPESSORE Thickness	SCATOLE Boxes			PALETTE Pallets		
		pcs	m ²	kg	box	m ²	kg
30x60 R9 / R11	8,3	8	1,44	24,00	40	57,60	978
21,6x21,6 / R9	8,8	28	1,31	24,50	60	78,60	1488
60x60 2cm	20	2	0,72	33,00	32	23,04	1074



Polinesia



Denpasar



Singaraya



Padang



Jambi



Medanji

GRIP R11

GRIP R11



FLOOR | **SINGARAYA + DENPASAR**



FLOOR | **SINGARAYA** | 30x60

30X60
21,6x21,6

Polinesia

Gres Porcellanato / Porcelain stoneware / Grès cérame / Feinsteinzeug

8,3 mm

NATURALE
R11 / A+B+C

SINGARAYA NAT R9



30x60 SINGARAYA
IPBP01S / NAT / R9

■ 59

PADANG GRIP R11



30x60 PADANG
IPBP11S / GRIP / R11 / A+B

■ 59

30x60
[16 FACCE]

Pezzi Speciali
[Special items]

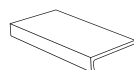

■ 28

IPBP20 ELLE PADANG

Elle Monolitico
15x30x4



8pz

Skirting
Battiscopa

IPBB01 BATT. SINGARAYA ■ 10

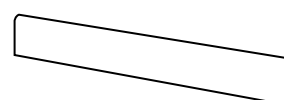

7,2x30 / 3"x12"



30 pz

DENPASAR

NAT R9

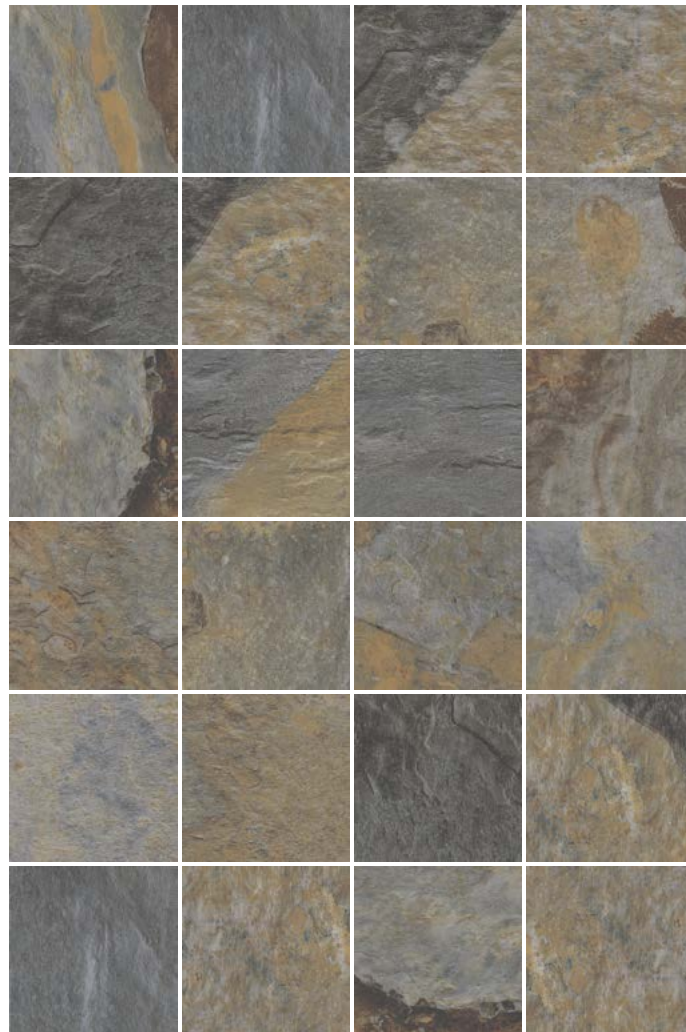

21,6x21,6 DENPASAR
IPBP02 / NAT / R9

■ 64

21,6x21,6
[18 FACCE]

Mosaico (30x30)

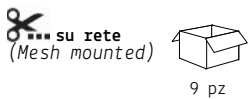

5x5 MOS. PADANG GRIP
IPBM11 / R11 ■ 21

R11

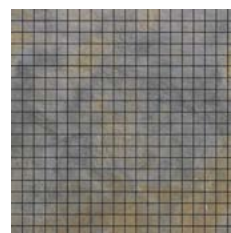

1,5x1,5 MOS. SINGARAYA
IPBM01 / NAT / R9 ■ 43

R9

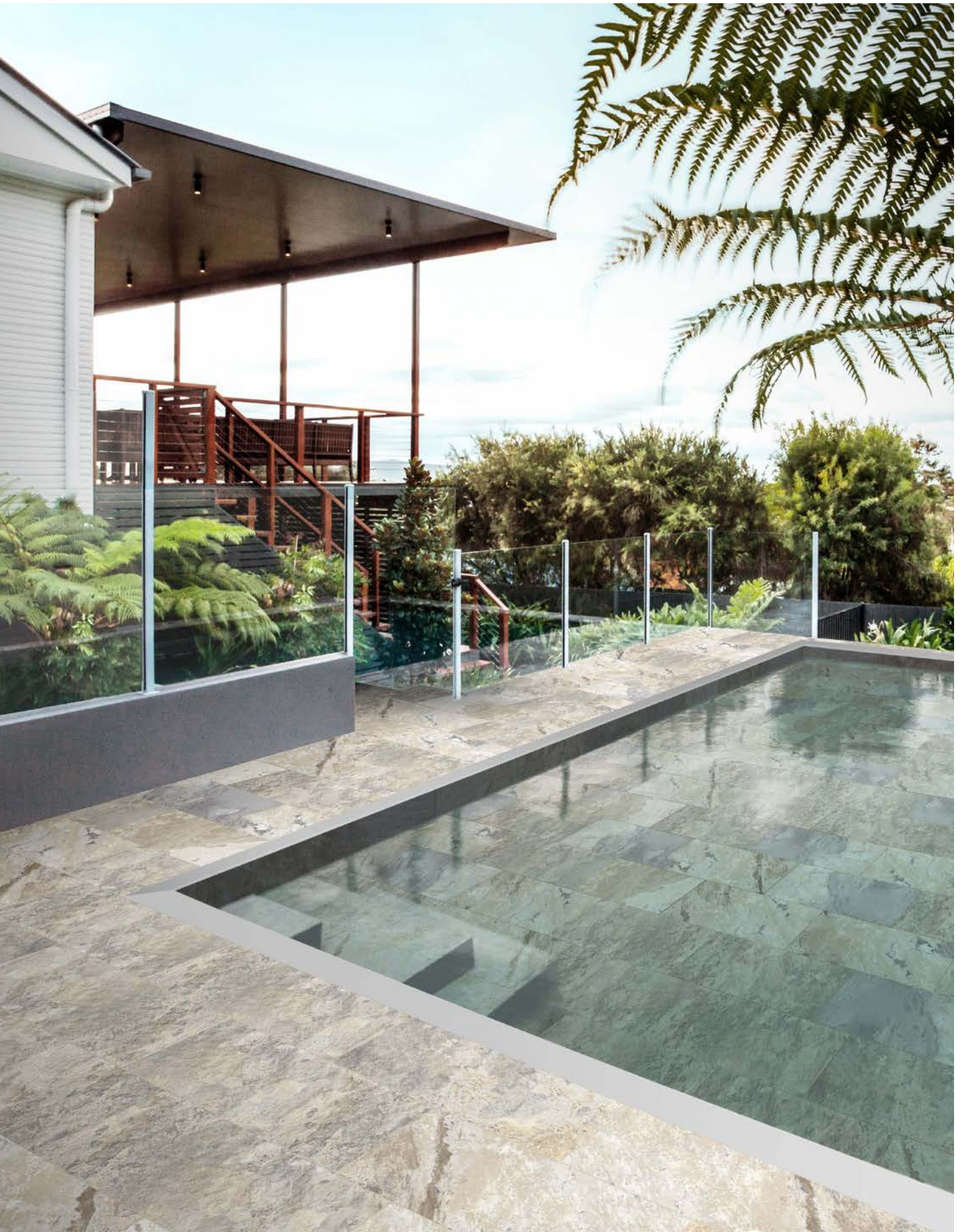

FLOOR | **JAMBI** | 30x60



FLOOR | **MEDANJI** | 30x60

Medanji & Jambi

MEDANJI

NAT R9

JAMBI

GRIP R11



30x60 MEDANJI
IPBP04S / NAT / R9

■ 59



30x60 JAMBI
IPBP14S/ GRIP R11 / A+B+C

■ 59

30x60



[13 FACCE]

Skirting
Battiscopa

IPBB04 BATT. MEDANJI ■ 10

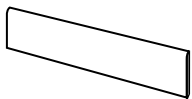

7,2x30 / 3"x12"



30 pz

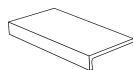

■ 28

IPBP24 ELLE JAMBI GRIP

Elle Monolitico
15x30x4



8 pz



5x5 MOS. JAMBI GRIP
IPBM14 / R11 ■ 21

R11

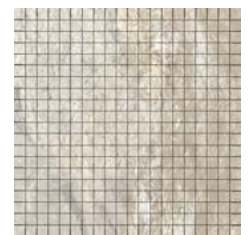

1,5x1,5 MOS. MEDANJI
IPBM04 / NAT / R9 ■ 43

R9



9 pz

POLINESIA | 2 CM

▼
20 mm
▲
RET / R11
A + B + C

2cm | 60x60



PADANG
GRIP R11

JAMBI
GRIP R11

60x60

60x60



60X60 POLINESIA PADANG
IPBP10 / RET █ 91

60X60 POLINESIA JAMBI
IPBP16 / RET █ 91



TORO 180°



30x60

IPBT10 PADANG / GRIP / TORO 180°

IPBT16 JAMBI / GRIP / TORO 180°

FORMATO Size	SPESSORE Thickness	SCATOLE Boxes			PALETTE Pallets		
		pcs	m ²	kg	box	m ²	kg
60x60 2cm	20	2	0,72	33,00	32	23,04	1074

JAMBI | 60x60 2CM

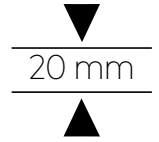

RET / R11
A + B + C

JAMBI
GRIP R11



TORO 180°



30x60

IPBT16 JAMBI / GRIP / TORO 180°

60X60 POLINESIA JAMBI ■ 91
IPBP16 / RET



PADANG | 60x60 2CM

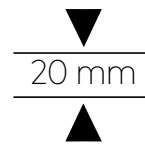

RET / R11
A + B + C

PADANG
GRIP R11



TORO 180°



30x60

IPBT10 PADANG / GRIP / TORO 180°

60X60 POLINESIA PADANG ■ 91
IPBP10 / RET

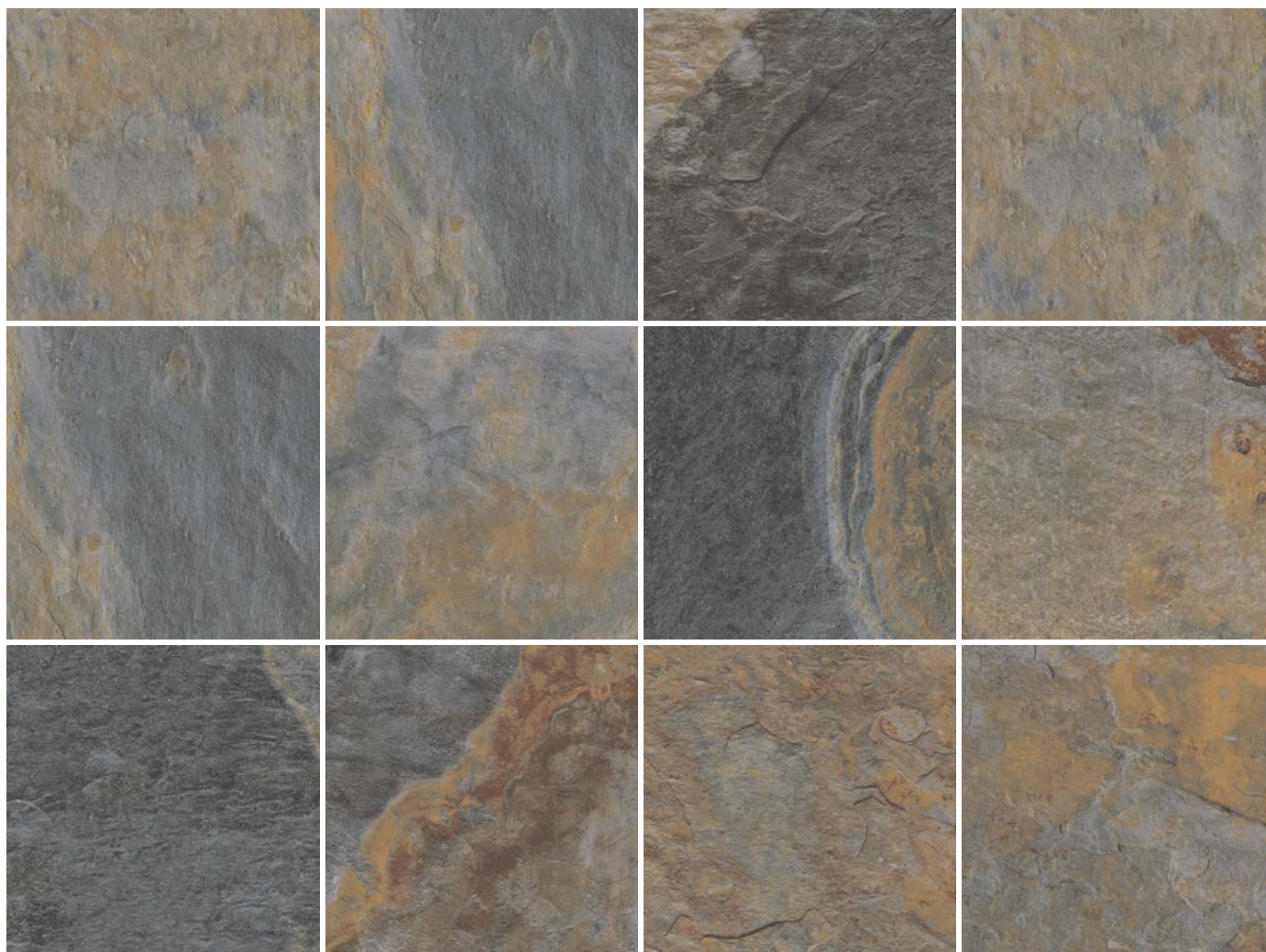



Web site
More info

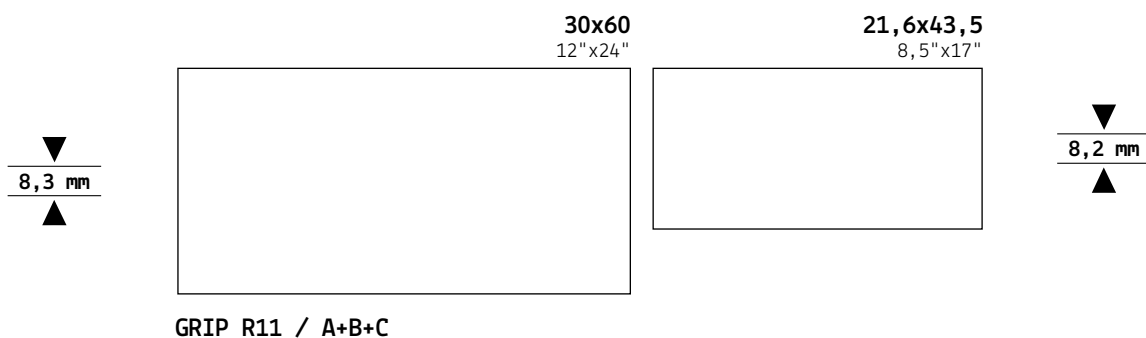

METROPOLIS

Gres Porcellanato
Porcelain stoneware
Grès cérame
Feinsteinzeug



FORMATO Size	SPESSORE Thickness	SCATOLE Boxes 			PALETTE Pallets 				
		cm	mm	pcs	m ²	kg	box	m ²	kg
30x60	8,3			8	1,44	24,00	40	57,60	978
30x60 RIGA	8,3			6	1,08	18,00	48	51,84	882
30x60 RIGA [B]	8,3			7	1,26	21,00	40	50,40	858
21,6x43,5	8,2			15	1,41	21,60	56	78,96	1209



Metropolis









Beige

Tortora

Grigio

Antrax

30x60 [4 colori]

22x44 [3 colori]



Beige

Tortora

Grigio

Antrax

Metropolis

30x60

Muretto Riga

30X60
21,6x43,5

METROPOLIS

Gres Porcellanato / Porcelain stoneware / Grès cérame / Feinsteinzeug

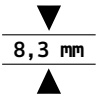
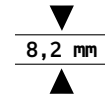

[21,6x43,5]

NATURALE

R11 / A+B+C

R11 / A+B+C



30x60 TORTORA
IMEP10S / GRIP / R11

■ 59



30x60 RIGA TORTORA
IMERO4B / GRIP / R11

■ 62



21,6x43,5 TORTORA
IMEP01N / GRIP / R11

■ 59



30x60 BEIGE
IMEP11S / GRIP / R11

■ 59



30x60 RIGA BEIGE
IMERO1B / GRIP / R11

■ 62



21,6x43,5 BEIGE
IMEP02N / GRIP / R11

■ 59



30x60 GRIGIO
IMEP12S / GRIP / R11

■ 59



30x60 RIGA GRIGIO
IMERO2 / GRIP / R11

■ 62



21,6x43,5 GRIGIO
IMEP03N / GRIP / R11

■ 59



30x60 ANTRAX
IMEP13S / GRIP / R11

■ 59



30x60 RIGA ANTRAX
IMERO3B / GRIP / R11

■ 62

Pezzi Speciali
[Special items]

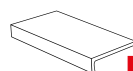

■ 28

Elle Monolitico
15x30x4
pcs/box 8

IMEP20 TORTORA
IMEP30 BEIGE
IMEP40 GRIGIO
IMEP20 ANTRAX

METROPOLIS



FLOOR | METROPOLIS **BEIGE** + **RIGA BEIGE** | 30x60

Web site
More info

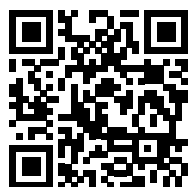

43,5x21,6
17"x8,5"



▼
8,2 mm
▲

POLAR

Gres Porcellanato
Porcelain stoneware
Grès cérame
Feinsteinzeug



FORMATO
Size

cm
43,5x21,6

SPESSORE
Thickness

mm
8,2

SCATOLE
Boxes

pcs m² kg
15 1,41 21,60



PALETTE
Pallets



box m² kg
56 78,96 1227

POLAR

Gres Porcellanato / Porcelain stoneware
Grès cérame / Feinsteinzeug

▼
8,2 mm
▲

NATURALE
R11 / A+B+C

SAND



21,6x43,5 SAND
IPOP05N / GRIP / R11 ■ 64

SILVER



21,6x43,5 SILVER
IPOP06N / GRIP / R11 ■ 64

SMOKE



21,6x43,5 SMOKE
IPOP07N / GRIP / R11 ■ 64

ANTRAX

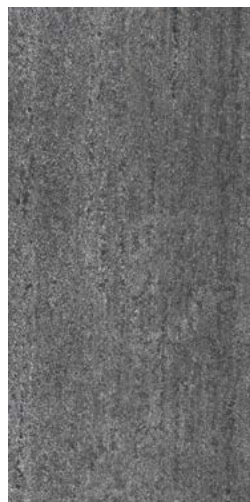

21,6x43,5 ANTRAX
IPOP08N / GRIP / R11 ■ 64

Pezzi Speciali
[Special items]

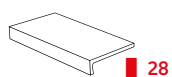

■ 28

Elle Monolitico
15x30x4
pcs/box 8

IPOP13 SAND
IPOP14 SILVER
IPOP15 SMOKE
IPOP16 ANTRAX

Web site
More info

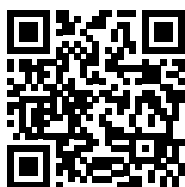

ETERNA

Gres Porcellanato
Porcelain stoneware
Grès cérame
Feinsteinzeug

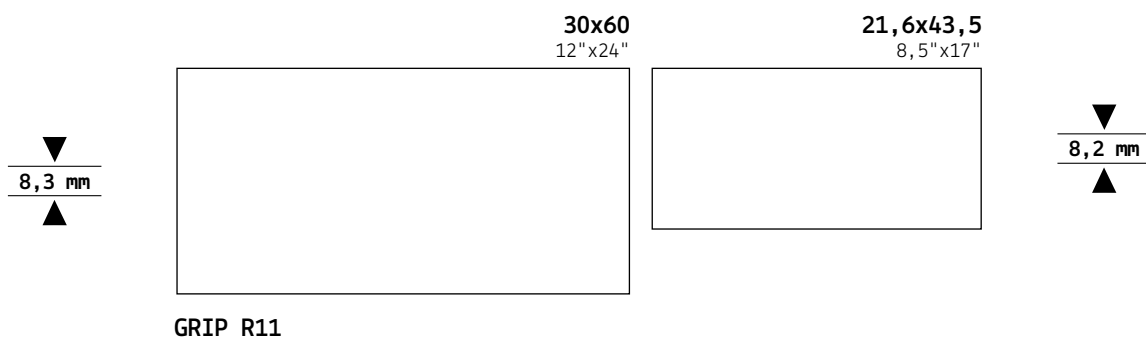

FORMATO Size	SPESSORE Thickness	SCATOLE Boxes			PALETTE Pallets		
		pcs	m ²	kg	box	m ²	kg
30x60 [DRITTO]	8,3	8	1,44	24,00	40	57,60	978
21,6x43,5 [ONDULATO]	8,2	15	1,41	21,60	56	78,96	1227



Eterna

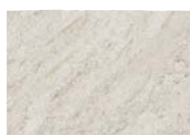

Bianco



Beige



Grigio



FLOOR | ETERNA **BEIGE** | 30x60



30X60
21,6x43,5

ETERNA

Gres Porcellanato / Porcelain stoneware / Grès cérame / Feinsteinzeug

▼
8,3 mm
▲
NATURALE
R11

Naturale + **Bordo Dritto**



30x60 BIANCO
IETP04S / GRIP / R11

■ 59

Naturale + **Bordo Ondulato**



21,6x43,5 BIANCO
IETP01 / GRIP / R11

■ 59



30x60 BEIGE
IETP05S / GRIP / R11

■ 59



21,6x43,5 BEIGE
IETP02 / GRIP / R11

■ 59



30x60 GRIGIO
IETP06S / GRIP / R11

■ 59



21,6x43,5 GRIGIO
IETP03 / GRIP / R11

■ 59

▼
8,2 mm
▲

[21,6x43,5]
R11 / A+B+C

Pezzi Speciali
[Special items]

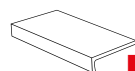

■ 28

Elle Monolitico
15x30x4
pcs/box 8

IETP11 BIANCO
IETP12 BEIGE
IETP13 GRIGIO

ETERNA

Naturale + **Bordo Ondulato**



PIETRA DI BISMANTOVA

Gres Porcellanato
Porcelain stoneware
Grès cérame
Feinsteinzeug

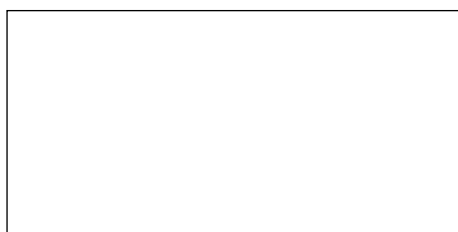

30x60
12"x24"

▼
8,3 mm
▲

GRIP R11



FORMATO
Size

cm
30x60

SPESSORE
Thickness

mm
8,3

SCATOLE
Boxes

pcs
8



m² kg
1,44 24,00

PALETTE
Pallets



box m² kg
40 57,60 978



Pietra di Bismantova





FLOOR | **PIETRA DI BISMANTOVA** | 30x60

PIETRA DI BISMANTOVA

GRIP R11

PIETRA DI BISMANTOVA | 30x60

▼
8,3 mm
▲



30x60 P. DI BISMANTOVA
IETP075 / NAT / R11 GRIP

■ 59

Pezzi Speciali
[Special items]

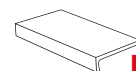

■ 28

Elle Monolitico
15x30x4
pcs/box 8

IETP14 P.di Bismantova

Web site
More info

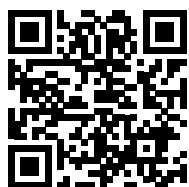

COTTI D'EREMO

Gres Porcellanato
Porcelain stoneware
Grès cérame
Feinsteinzeug



22x44
16"x24"

▼
8,2 mm
▲

R10 + R11



FORMATO

Size

cm

21,6x43,5 (R10)
21,6x43,5 (R11)

SPESSORE

Thickness

mm

8,2
8,2

SCATOLE

Boxes

pcs

m²

kg

15 1,41 21,60
15 1,41 21,60



PALETTE

Pallets

box

m²

kg

56 78,96 1227
56 78,96 1227





Cotti d'Eremo



Ocra

Rosso

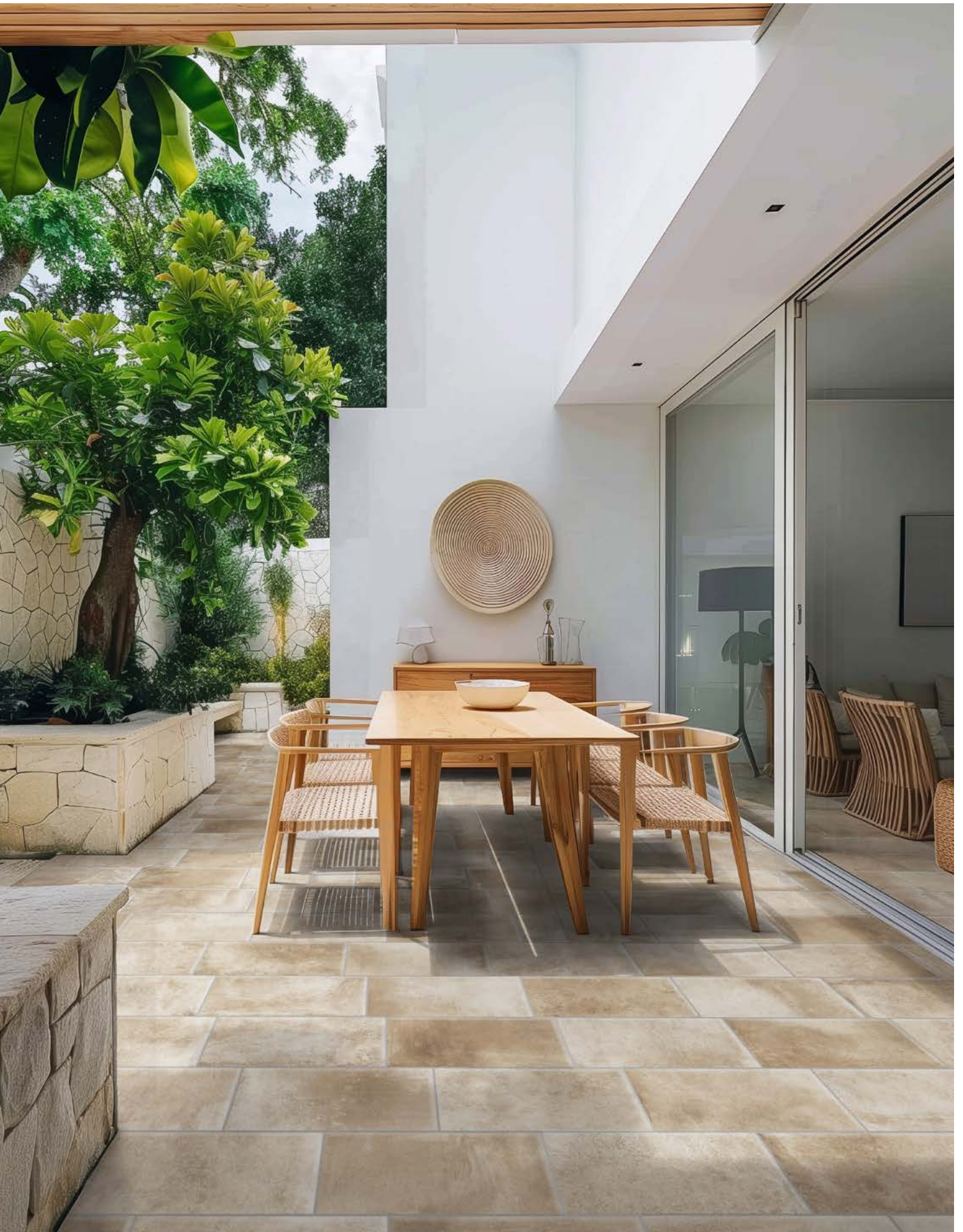

FLOOR | COTTI D'EREMO **OCRA** | 22x44



FLOOR | COTTI D'EREMO **ROSSO** | 22x44



FLOOR | COTTI D'EREMO **OCRA** | 22x44



FLOOR | COTTI D'EREMO **ROSSO** | 22x44

COTTI D'EREMO | 22x44

R10 + R11



INDOOR | INTERNO

R10

OCRA

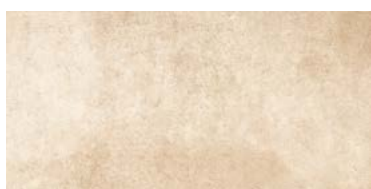

21,6x43,5 C.D'EREMO OCRA ■ 59
ICEP01 / R10

ROSSO



21,6x43,5 C.D'EREMO ROSSO ■ 59
ICEP02 / R10

OUTDOOR | ESTERNO

GRIP R11

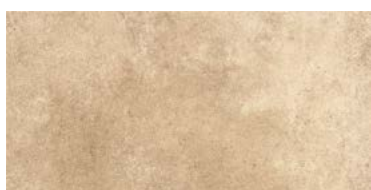

21,6x43,5 C.D'EREMO OCRA ■ 59
ICEP11 / R11 GRIP

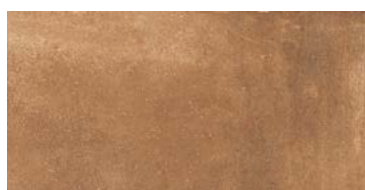

21,6x43,5 C.D'EREMO ROSSO ■ 59
ICEP12 / R11 GRIP

Elle Monolitico
15x30x4
pcs/box 8

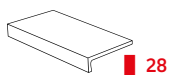

ICEP14 OCRA R11
ICEP13 ROSSO R11

COTTI D'EREMO



OCRA

ROSSO

Web site
More info

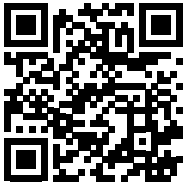

PALINURO

Gres Porcellanato
Porcelain stoneware
Grès cérame
Feinsteinzeug

34x34
13,3"x13,3"

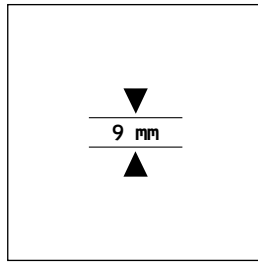

V4





PEI 4

◆◆ Glossy
LUCIDO

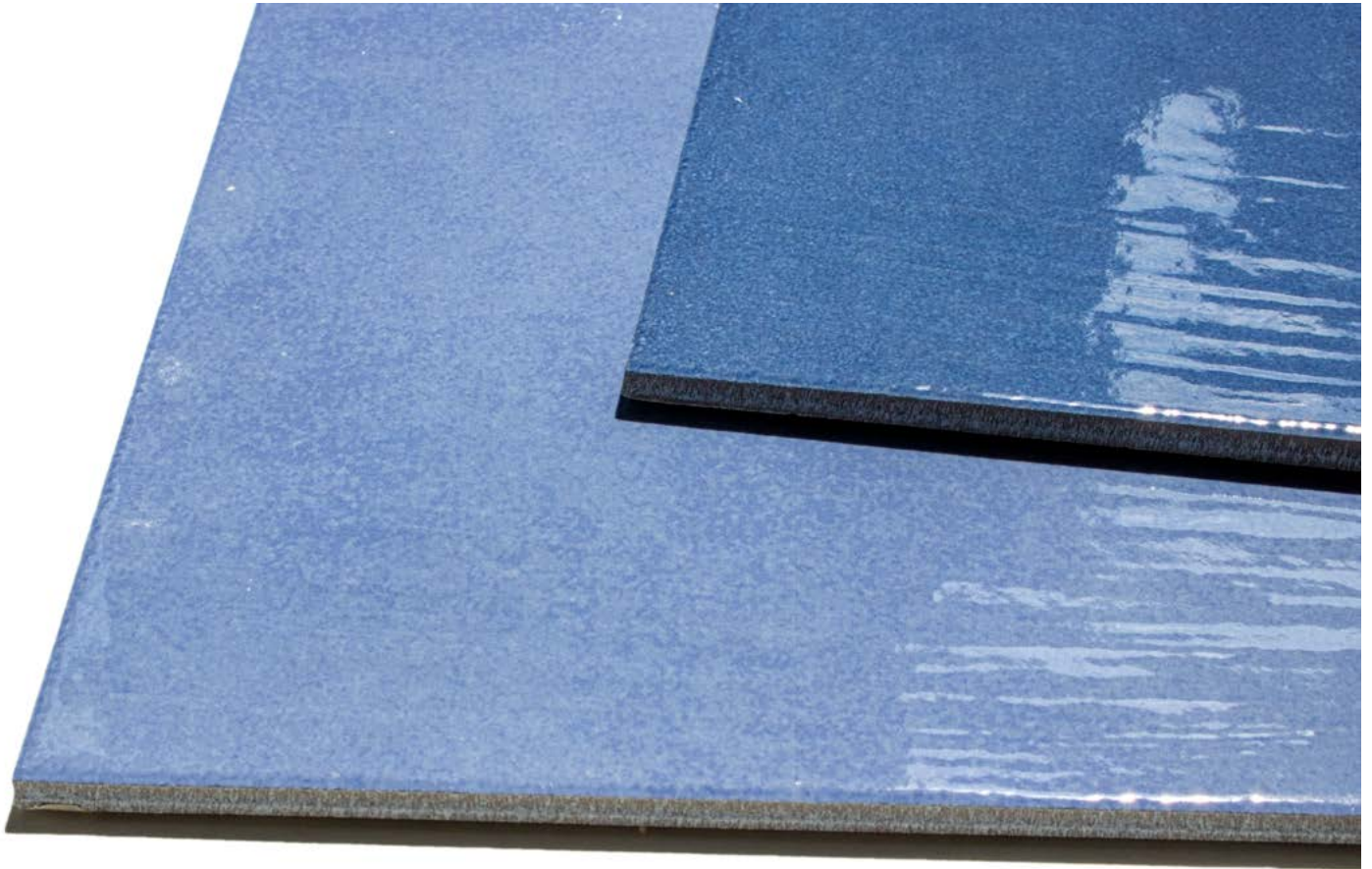
NATURALE
R9 / R11



FORMATO Size	SPESSORE Thickness	SCATOLE Boxes		PALETTE Pallets			
cm	mm	pcs	m ²	kg	box	m ²	kg
34x34	9	12	1,39	24,05	44	61,16	1076



Palinuro



Bianco



Acquamarina



Azzurro



Blu Notte



camerota



FLOOR | PALINURO **ACQUAMARINA** | 34x34



FLOOR | PALINURO **AZZURRO** + PALINURO DEC **CAMEROTA** | 34x34

PALINURO | 34x34

▼
9 mm
▲
NATURALE
R9 / R11

BIANCO



34x34 BIANCO
IPAP01 / NAT / R9 ■ 82
IPAP05 / GRIP / R11 ■ 82

AZZURRO



34x34 AZZURRO
IPAP03 / NAT / R9 ■ 82
IPAP07 / GRIP / R11 ■ 82

ACQUAMARINA



34x34 ACQUAMARINA
IPAP02 / NAT / R9 ■ 82
IPAP06 / GRIP / R11 ■ 82

BLU NOTTE



34x34 BLU NOTTE
IPAP04 / NAT / R9 ■ 82
IPAP08 / GRIP / R11 ■ 82

CAMEROTA

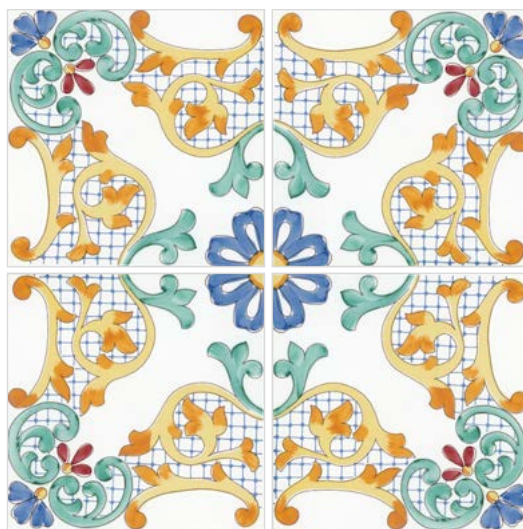

34x34 DEC. CAMEROTA
IPAP09 / NAT / R9 ■ 82
IPAP10 / GRIP / R11 ■ 82

PALINURO





idea
ceramica

COMMODITY | WALL & FLOOR

WEISS | 25x60

▼
8 mm
▲

Bicottura tradizionale / Traditional double fired / Traditionnelle bi-cuisson / Zweibrandfliesen

WEISS LUX

WEISS MATT

◆ Glossy
LUCIDO

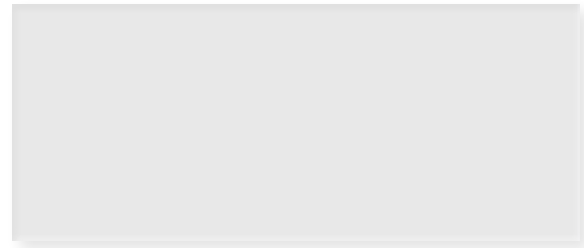
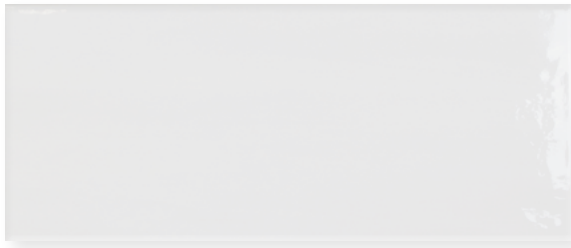

M0000N WEISS LUX 25x60 █ 53

M0005N WEISS MATT 25x60 █ 53

◆ Glossy
LUCIDO

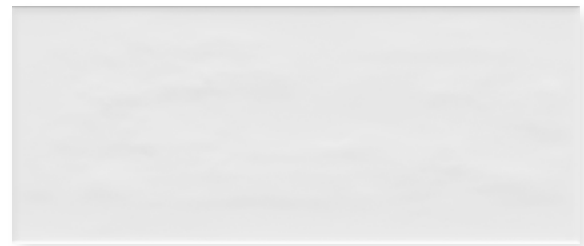
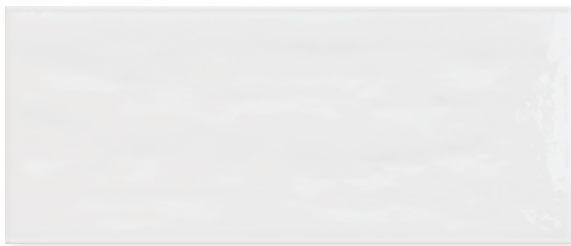

M0010N WEISS WAVE LUX 25x60 █ 60

M0015N WEISS WAVE MATT 25x60 █ 60

WAVE LUX

WAVE MATT

WHITE and WHITE | 25x40

▼
7 mm
▲

Bianco
CLASSICO

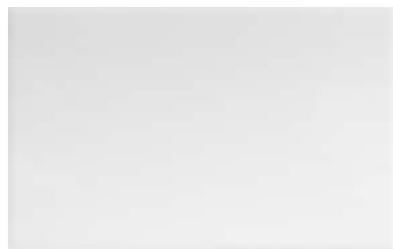

Bianco
CLASSICO
MATT

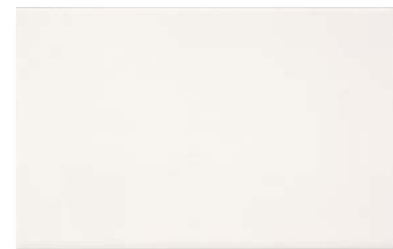

WC000A Bianco Classico 25x40 █ 39

WW100A Bianco Classico Matt. 25x40 █ 39

WHITE SPRING | 20x40

▼
6,2 mm
▲

◆ Glossy
LUCIDO

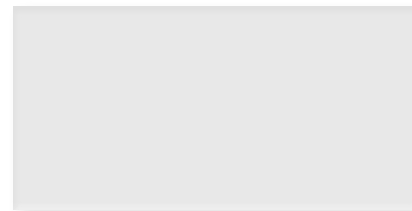
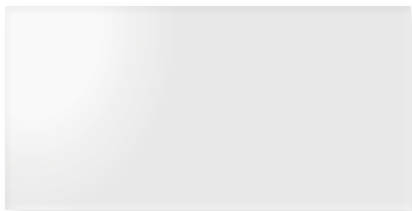

M0020E White Spring WHITE LUX 20x40 █ 39

M0025E White Spring WHITE MATT 20x40 █ 39

FORMATO Size	SPESSORE Thickness	SCATOLE Boxes	SCATOLE		PALETTE Pallets	PALETTE		Imballi / Pesì [Packaging / Weights]
			pcs	m ²		box	m ²	
cm	mm			kg				
25x60 WEISS	8	10	1,50	20,00	48	72,00	978	
25x40 WHITE and WHITE	7	17	1,70	19,35	54	91,80	1063	
20x40 WHITE SPRING	6,2	20	1,60	16,40	64	102,4	1067,6	

BRAVA | 25x60

▼
8 mm
▲



BEIGE



GB240 - M.CL003 BRAVA BEIGE / 25x60 ■ 62



GB262 - BRAVA ONDA BEIGE / 25x60 ■ 73



GB261 - BRAVA ASTORIA BEIGE / 25x60 ■ 73

GRIGIO



GB235 - M.CL001 BRAVA GRIGIO / 25x60 ■ 62



GB257 - BRAVA ONDA GRIGIO / 25x60 ■ 73



GB256 - BRAVA ASTORIA GRIGIO / 25x60 ■ 73

FORMATO Size	SPESSORE Thickness	SCATOLE Boxes			PALETTE Pallets		
		pcs	m ²	kg	box	m ²	kg
25x60 BRAVA	8	10	1,50	20,00	48	72,00	978
25x60 STRUTTURE	8	10	1,50	20,00	48	72,00	978

Inballi / Pesì
[Packaging / Weights]



WHITE AND WOOD

Bicottura tradizionale
Traditional double fired
Bi-cuisson traditionnelle
Zweibrandfliesen

Monocalibro / Monocaliber / Monocalibre / In einem werkmass

▼
7mm
▲



25x40
10"x16"



WHITE AND WOOD | 25x40

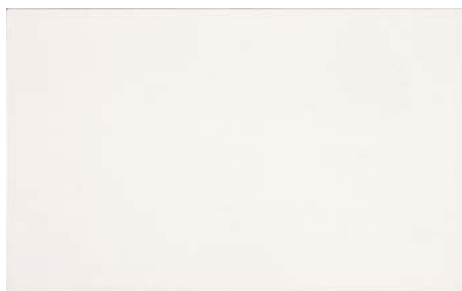
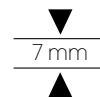

WW100A Bianco Classico Matt. ■ 39



WW400A Wood Grey ■ 39



WW300A Wood Cream ■ 39



WW410A Brick Grey / 25x40 ■ 46



WW310A Brick Cream / 25x40 ■ 46



WW405 Sigaro Cenere 3x40 ■ 10



WW305 Sigaro Noce / 3x40 ■ 10

FORMATO Size

cm

25x40 FONDI
25x40 BRICK
3x40 SIGARO

SPESSORE Thickness

mm

7
7
-

SCATOLE Boxes

pcs

17
17
8

m²

1,70
1,70
-

kg

19,35
19,35
1,44



PALETTE Pallets

box

54
54
-

m²

91,80
91,80
-

kg

1063
1063
-



Inballi / Pesì
[Packaging / Weights]



ANTARES | 20x50



Bicottura tradizionale / Traditional double fired / Traditionnelle bi-cuisson / Zweibrandfliesen



AW200 Antares **BLANC** 20x50 **46**



AW100 Antares **NOIR** 20x50 **46**



AW500 Antares **TAUPE** 20x50 **46**



AW300 Antares **GRIS** 20x50 **46**



IAND11 Decoro **TAUPE** 20x50 **61**



IAND10 Decoro **GRIS** 20x50 **61**



AW501 List. Antares **TAUPE** 4,5x50 **12**



AW301 List. Antares **GRIS** 4,5x50 **12**

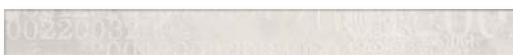

AW201 List. Antares **BLANC** 4,5x50 **12**

FORMATO Size	SPESSORE Thickness	SCATOLE Boxes			PALETTE Pallets		
		pcs	m ²	kg	box	m ²	kg
20x50 ANTARES	7	16	1,60	18,50	48	76,80	906
4,4x50 List.	7	8	0,10	2,06	-	-	-

Imballi / Pesì
[Packaging / Weights]



Monocalibro / Monocaliber / Monocalibre / In einem werkmass

Glossy
LUCIDO

VICKY | 20x50



Bicottura tradizionale / Traditional double fired / Traditionnelle bi-cuisson / Zweibrandfliesen

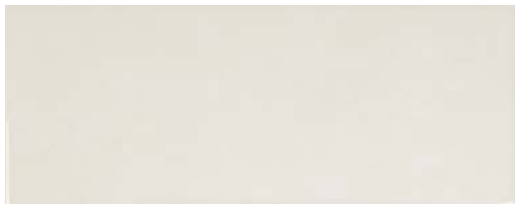

VKR100 Vicky **NEUTRO** 20x50 **50**



VKR100 Vicky **NEUTRO** 20x50 **50**



VKR101 Vicky **BEIGE** 20x50 **50**



VKR102 Vicky **GRIGIO** 20x50 **50**

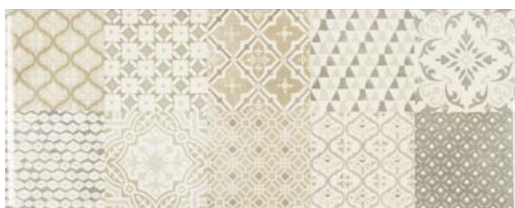

VKR103 Vicky **DECORO** 20x50 **61**

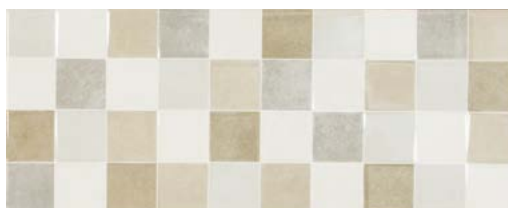

VKR104 Vicky **STRUTT. MIX** 20x50 **61**

FORMATO Size	SPESSORE Thickness	SCATOLE Boxes			PALETTE Pallets		
		pcs	m ²	kg	box	m ²	kg
20x50 VICKY	7	16	1,60	18,50	48	76,80	906

Imballi / Pesì
[Packaging / Weights]



Monocalibro / Monocaliber / Monocalibre / In einem werkmass

20X50

FLORA

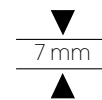

Bicottura tradizionale / Traditional double fired / Traditionnelle bi-cuisson / Zweibrandfliesen



IFLR20 - FLORA MUR. GRIGIO / 20x50 ■ 61



IFLR10 - FLORA MUR. BEIGE / 20x50 ■ 61



IFLR03 - FLORA PERLA / 20x50 ■ 46



IFLR02 - FLORA BEIGE / 20x50 ■ 46

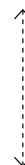
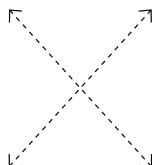
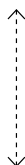

IFLR01 - FLORA AVORIO / 20x50 ■ 46

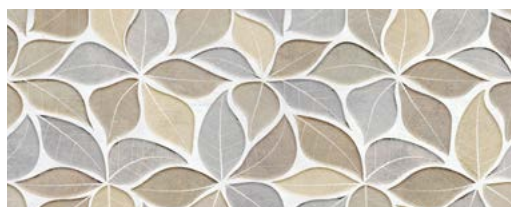

IFLD01 - FLORA DEC. UNIVERSAL / 20x50 ■ 61

FORMATO
Size

cm
20x50 FLORA

SPESSORE
Thickness

mm
7

SCATOLE
Boxes

pcs m²
16 1,60



kg
18,50

PALETTE
Pallets

box m² kg
48 76,80 906



Imballi / Pesì
[Packaging / Weights]



Monocalibro / Monocaliber / Monocalibre / In einem werkmass



Perla

Avorio

Universal



Beige

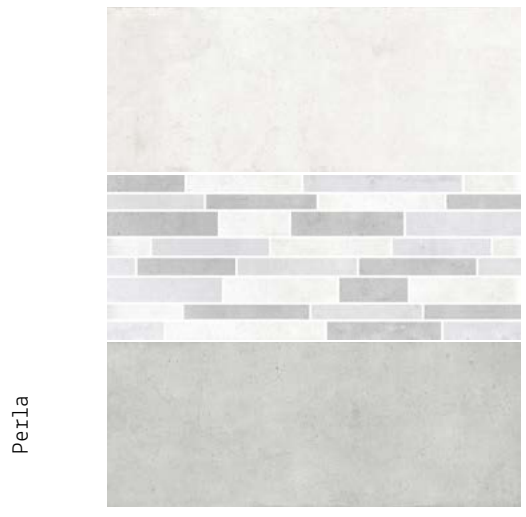

Perla

Avorio

Muretto



Beige

FLORA
Muretto

4 faces
4 facce



FLORA
Universal

1 face
1 faccia



Ripetibile / Verticale / Orizzontale
Seamless / Vertical / Horizontal

OUT e IN

Ceiba



V2

Gres Porcellanato
Porcelain stoneware
Grès cérame
Feinsteinzeug



PEI 4

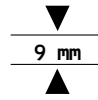

NATURALE / R11 / A+B+C

15x60
6"x24"

Grey Kane



Pezzi Speciali

[Special items]

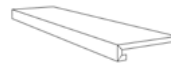

94
GRADINO
Costa Retta
15x60



116
ANGOLARE
DX / SX
15x60



63
ELLE
Costa Retta
15x60

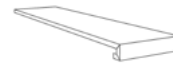

78
GRADINO 15x60
Costa Retta
lato corto

Emeri



8
Battiscopa
8x45
pcs/box 30
Kg 14,6

OY105 EMERI
OY205 CEIBA
OY305 GREY KANE

Consigli di posa / Conseils de pose / Verlegeempfehlungen

Installation advise **OK**

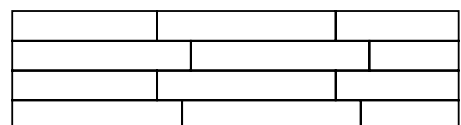

Installation advise **NO 50%**

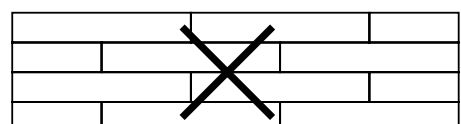

Imballi / Pesì
[Packaging / Weights]

FORMATO Size	SPESSORE Thickness	SCATOLE Boxes			PALETTE Pallets		
		pcs	m ²	kg	box	m ²	kg
15x60	9	12	1,08	17,60	60	64,80	1074

OUT & IN | 15x60

Gres Porcellanato / Porcelain stoneware / Grès cérame / Feinsteinzeug

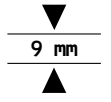

NATURALE
R11 / A+B+C

Ceiba



0Y2005 Out&in CEIBA / 15x60 ■ 61

Grey Kane



0Y3005 Out&in GREY KANE / 15x60 ■ 61

Emeri



0Y1005 Out&in EMERI / 15x60 ■ 61



V2



PEI 4

NOTTINGHAM

Gres Porcellanato
Porcelain stoneware
Grès cérame
Feinsteinzeug

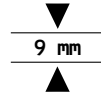

NATURALE / R10

15x60
6"x24"

Pezzi Speciali [Special items]

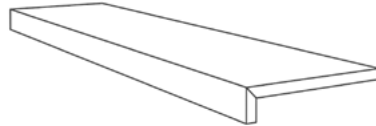

■ 63

Elle costa retta

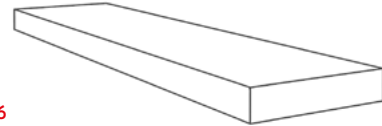

■ 116

Angolare DX e SX

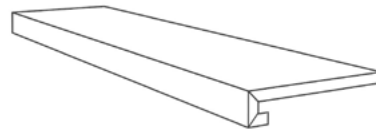

■ 94

Gradino costa retta

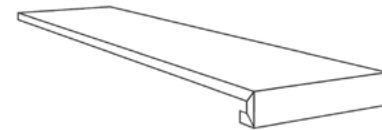

■ 78

Gradino costa retta
lato corto

Pezzi Speciali [Special items]

Battiscopa
8x45
pcs/box 30
Kg 14,6

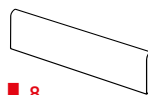

■ 8

NG105 MILK
NG205 ALMOND
NG305 WALNUT
NG405 TAUPE
NG505 STONE

Consigli di posa / Conseils de pose / Verlegeempfehlungen

Installation advise

NO 50%

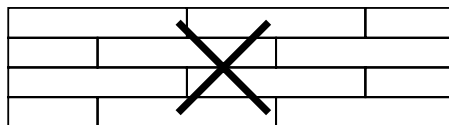

OK

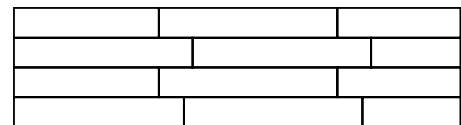

FORMATO
Size

SPESORE
Thickness

SCATOLE
Boxes



PALETTE
Pallets



Imballi / Pesì
[Packaging / Weights]

cm

mm

pcs

m²

kg

box

m²

kg

15x60

9

12

1,08

17,60

60

64,80

1074

NOTTINGHAM | 15x60

Gres Porcellanato / Porcelain stoneware / Grès cérame / Feinsteinzeug

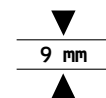

NATURALE
R10

Milk



NG100S Nottingham MILK / 15x60 ■ 60

Stone



NG500S Nottingham STONE / 15x60 ■ 60

Almond



NG200S Nottingham ALMOND / 15x60 ■ 60

Walnut



NG300S Nottingham WALNUT / 15x60 ■ 60

Taupe



NG400S Nottingham TAUPE / 15x60 ■ 60

BALI

Gres Porcellanato / Porcelain stoneware / Grès cérame / Feinsteinzeug

▼
8,5 mm
▲

60X60

NAT / R9 + R11

Bali AVANA

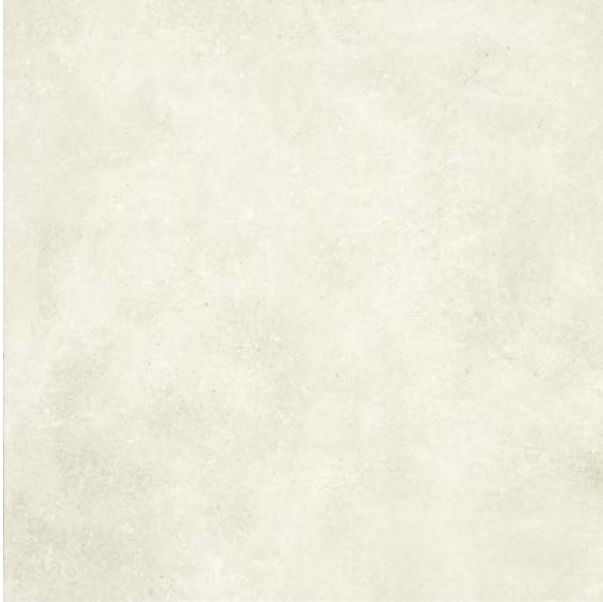

AAA100C Bali AVANA
60x60

■ 60

Bali SILVER

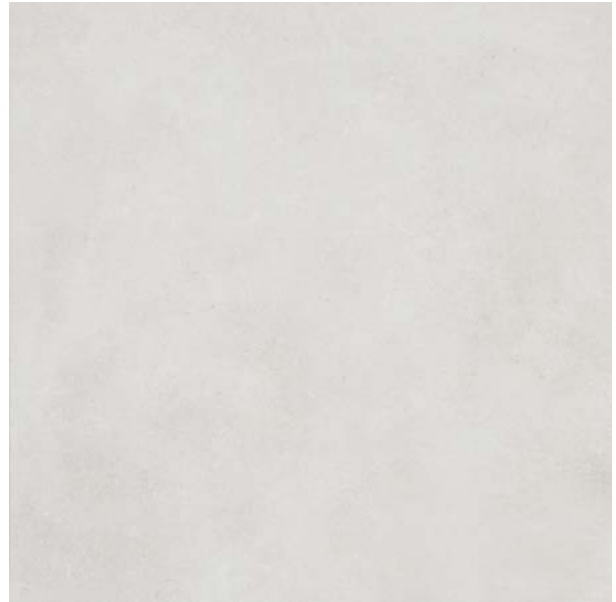

AAA300C Bali SILVER
60x60

■ 60

Bali VISIONE



60x60 Bali VISIONE
AAA200C / NAT / R9
AAA210C / GRIP R11

■ 60

Bali PIOMBO

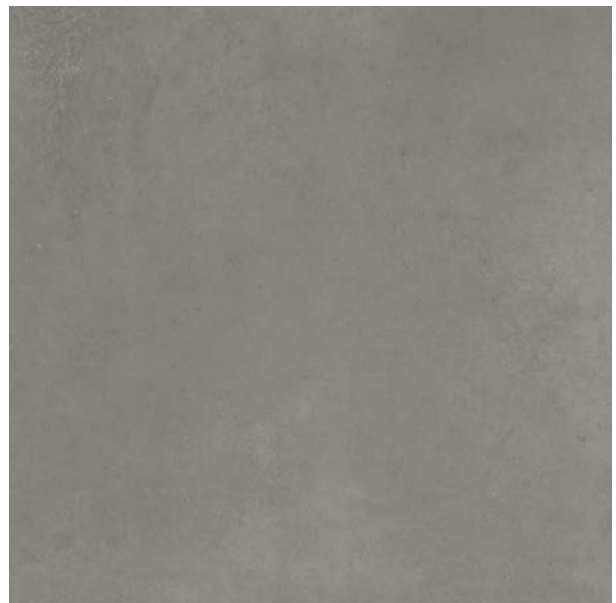

60x60 Bali PIOMBO
AAA400C / NAT / R9
AAA410C / GRIP R11

■ 60

BALI

Gres Porcellanato / Porcelain stoneware / Grès cérame / Feinsteinzeug

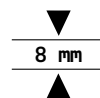

30X60

NAT / R9

BaLi AVANA



AAA150C Bali AVANA ■ 60
30X60

BaLi SILVER



AAA350C Bali SILVER ■ 60
30X60

BaLi VISIONE



AAA250C Bali VISIONE ■ 60
30X60

BaLi PIOMBO



AAA450C Bali PIOMBO ■ 60
30X60

Pezzi Speciali
[Special items]

Skirting
Battiscopa



13

Battiscopa
7,5x60
pcs/box 15

AAAB100C AVANA
AAAB200C VISIONE
AAAB300C SILVER
AAAB400C PIOMBO

FORMATO Size	SPESSORE Thickness	SCATOLE Boxes			PALETTE Pallets		
		pcs	m ²	kg	box	m ²	kg
60x60	8,5	4	1,44	26,50	30	43,20	813
30x60	8	8	1,44	24,00	40	57,60	978

Imballi / Pesi
[Packaging / Weights]

PEI 4

RIFLESSI | 45,5x45,5

Gres Porcellanato / Porcelain stoneware / Grès cérame / Feinsteinzeug

▼
8,2 mm

▲
NATURALE
R9

Riflessi BEIGE



FRBE425 Riflessi BEIGE ■ 50
45,5x45,5

Riflessi GRIGIO



FRGR425 Riflessi GRIGIO ■ 50
45,5x45,5



IRIB02 Riflessi BEIGE Batt. ■ 10
7,5x45



IRIB01 Riflessi GRIGIO Batt. ■ 10
7,5x45

**SKIRTING
BATTISCOPA**
7,5x45



30 pz

FORMATO Size	SPESSORE Thickness	SCATOLE Boxes				PALETTE Pallets			
cm	mm	pcs	m ²	kg	box	m ²	kg		
45,5x45,5	8,2	8	1,66	26,24	48	79,68	1278		

Imballi / Pesì
[Packaging / Weights]

PEI 4

ALPI | 60X60 | Rettificato

Gres Porcellanato / Porcelain stoneware / Grès cérame / Feinsteinzeug

▼
7,5 mm

▲
RETTIFICATO
R9

Alpi BEIGE



PF00021813 - CL003 Alpi BEIGE ■ 66
60x60 | RET

Alpi GRIGIO



PF00021814 - CL005 Alpi GRIGIO ■ 66
60x60 | RET

Pezzi Speciali
[Special items]

**Skirting
Battiscopa**



■ 13

Battiscopa
8x60
pcs/box 15

IALB01 Batt.
Alpi Beige

IALB02 Batt.
Alpi Grigio

FORMATO Size	SPESSORE Thickness	SCATOLE Boxes				PALETTE Pallets			
cm	mm	pcs	m ²	kg	box	m ²	kg		
60X60	8,2	4	1,44	20,59	32	46,08	677		

Imballi / Pesì
[Packaging / Weights]

PEI 4

CARATTERISTICHE TECNICHE

Technical features
Caractéristiques techniques
Technische Eigenschaften

PAVIMENTO

Floor tile

RIVESTIMENTO

Wall tile



	Metodo di prova Testing method Méthode d'essai Prüfmethode	Valori prescritti International Standard Internationale Normwerte Valeurs Prescrites	Valori prescritti International Standard Internationale Normwerte Valeurs Prescrites	Valori medi Average Value Mittelwert Valeurs Moyennes
Assorbimento d'acqua Water absorption Absorption d'eau Wasseraufnahme	ISO 10545 - 3	≤ 0,5 %	> 10 %	Conforme In accordance Entsprechend
Lunghezza e larghezza Length and width Longueur et largeur Länge und Breite	ISO 10545 - 2	+/- 0,6 %	+/- 0,5 %	Conforme In accordance Entsprechend
Spessore Thickness Épaisseur Stärke	ISO 10545 - 2	+/- 5 %	+/- 10 %	Conforme In accordance Entsprechend
Rettilineità degli spigoli Straightness Equerrage des angles Geradlinigkeit	ISO 10545 - 2	+/- 0,5 %	+/- 0,3 %	Conforme In accordance Entsprechend
Ortogonalità Rectangularity Orthogonalité Rechtwinkligkeit	ISO 10545 - 2	+/- 0,6 %	+/- 0,5 %	Conforme In accordance Entsprechend
Planarità Warpage Planéité Ebenflächigkeit	ISO 10545 - 2	+/- 0,5 %	+/- 0,5 % - 0,3%	Conforme In accordance Entsprechend
Coefficiente di attrito (scivolosità) Friction coefficient (slipperiness) Coefficient de friction (glissement) Reibungskoeffizient (Schlupfrigkeit)				
Coefficiente dilatazione termica lineare Coefficient of linear thermal-expansion Coefficient de dilatation thermique linéaire Lineare Wärmeausdehnung	ISO 10545 - 8	9 MK ¹		7 MK¹
Resistenza alla flessione Flexion resistance Résistance à la flexion Biegezugfestigkeit	ISO 10545 - 4	> 35 N/mm ²	> 15 N/mm ²	Conforme In accordance Entsprechend
Resistenza all'abrasione profonda Deep abrasion resistance Résistance à l'abrasion profonde Beständigkeit gegen Tiefenabrieb				
Resistenza al gelo Frost resistance Résistance au gel Frostwiderstandsfähigkeit	ISO 10545 - 12	Nessuna alterazione No alteration		Conforme In accordance Entsprechend
Resistenza agli sbalzi termici Thermal shock resistance Résistance aux écarts de température Temperaturwechselbeständigkeit	ISO 10545 - 9	Nessuna alterazione No alteration		Conforme In accordance Entsprechend
Resistenza dei colori alla luce Color resistance to light Résistance de la couleur à la lumière Lichtbeständigkeit	DIN 51094	Nessuna alterazione No alteration		Conforme In accordance Entsprechend
Resistenza ai prodotti chimici Chemical resistance Résistance aux produits chimiques Chemikalienfestigkeit	ISO 10545 - 13	Classe UB min	Classe GB min	Conforme In accordance Entsprechend
Resistenza alle macchie Stain resistance Résistance aux taches Flecken-Beständigkeit	ISO 10545 - 14	Classe 3 min	Classe 3 min	Conforme In accordance Entsprechend

UNI EN 14411 G
Gruppo BIa GL

UNI EN 14411 L
Gruppo BIII GL

Pavimenti in gres porcellanato
Porcelain wall and floor tiles

Rivestimenti in bicottura
Double firing wall tiles

idea
ceramica

2cm | 60x60

20 mm

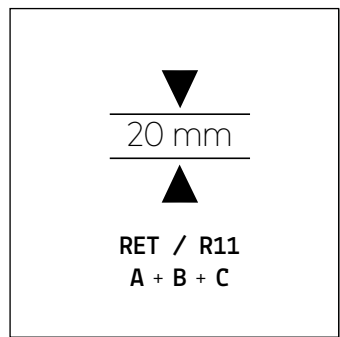

Gres Porcellanato
Porcelain stoneware
Grès cérame
Feinsteinzeug



TORO 180°



30x60

ISTT21 U.STONE GREYGE / GRIP / TORO 180°

ISTT16 U.STONE ALMOND / GRIP / TORO 180°

IDET07 DEA IVORY / GRIP / TORO 180°

IDET08 DEA GOLD / GRIP / TORO 180°

IPBT10 PADANG / GRIP / TORO 180°

IPBT16 JAMBI / GRIP / TORO 180°

2 centimetri

FORMATO
Size

cm

U. STONE 60x60

POLINESIA 60x60

DEA 60x60

SPESSORE
Thickness

mm

20

20

20

SCATOLE
Boxes

pcs

2

2

2

SCATOLE
Boxes

m²

0,72

0,72

0,72

kg

33,00

33,00

33,00

PALETTE
Pallets

box

32

32

32

m²

23,04

23,04

23,04

kg

1074

1074

1074



2cm | 60x60

GREYGE

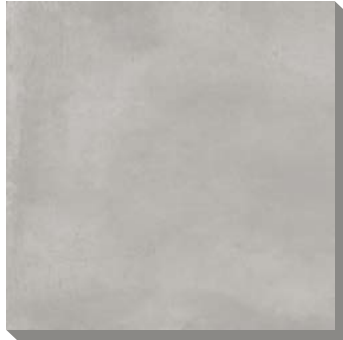

60X60 U.STONE GREYGE
ISTP21 / RET

■ 91

ALMOND



60X60 U.STONE ALMOND
ISTP20 / RET

■ 91

Pag.160

↑ URBAN STONE

IVORY



60x60 DEA IVORY
MCADE05 / GRIP / R11

■ 91

GOLD



60x60 DEA GOLD
MCADE06 / GRIP / R11

■ 91

Pag.214

↑ DEA

JAMBI



60X60 POLINESIA JAMBI
IPBP16 / RET

■ 91

PADANG



60X60 POLINESIA PADANG
IPBP10 / RET

■ 91

Pag.248

↑ POLINESIA

POSA SU ERBA
 Laying On Soil - Grass
 Pose Sur Terrain - Pelouse
 Verlegung Auf Erdreich - Grasnarbe



POSA SU SABBIA
 Laying On Sand
 Pose Sur Sable
 Verlegung Auf Sand

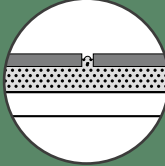

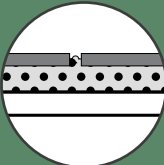

POSA SU GHIAIA
 Laying On Gravel
 Pose Sur Gravier
 Verlegung Auf Kies



POSA SU MASSETTO CON COLLA
 Installation Slabs On A Screed
 Pose De Dalles C Ramiques Sur Chape
 Anleitungen Für Die Verlegung Von
 Keramikplatten Auf Estrich

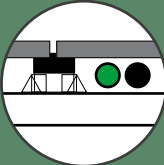

POSA SOPRAELEVATA
 Installation Of A Raised Floor For Exterior Locations
 La Pose D'un Plancher Sur Lev Pour
 Am Nagements Ext Rieurs
 Verlegung Von Schwimmendem Bodenbelag Für
 Aussenbereichemikplatten Auf Estrich





La forza del Gres Porcellanato, nello spessore maggiorato, offre l'opportunità di vestire gli spazi esterni in molteplici soluzioni e formati

SISTEMI DI POSA

Laying Instructions - Instructions De Pose - Verlegeanleitungen

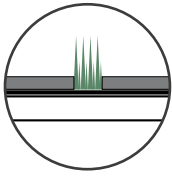
2cm | 60x60



POSA SU ERBA

Laying On Soil - Grass
Pose Sur Terrain - Pelouse
Verlegung Auf Erdreich - Grasnarbe

IDEA CERAMICA / Products / Prodotti / 20 mm
MANTO ERBOSO
GHIAIA Ø 4/8 mm (5/8 cm di spessore)
TERRENO

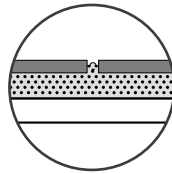
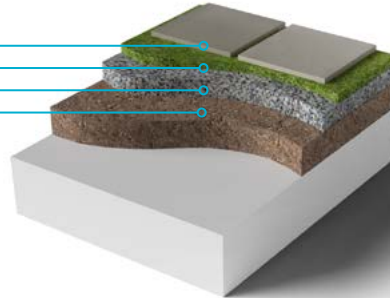

POSA SU SABBIA

Laying On Sand
Pose Sur Sable
Verlegung Auf Sand

IDEA CERAMICA / Products / Prodotti / 20 mm
SABBI (2/5 cm di spessore)
GHIAIA Ø 0/20 MM (20/40 cm di spessore)
GHIAIA Ø 40/80 MM (30/50 cm di spessore)
GEOTESSUTO
TERRENO

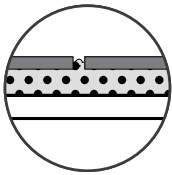
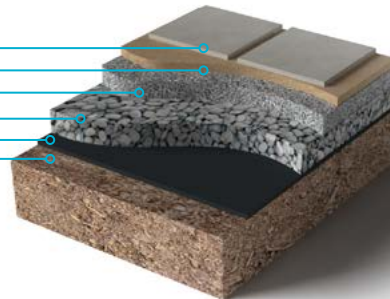

POSA SU GHIAIA

Laying On Gravel
Pose Sur Gravier
Verlegung Auf Kies

IDEA CERAMICA / Products / Prodotti / 20 mm
GHIAIA Ø 4/8 MM (10/30 cm di spessore)
TAPPETINO A NIDO D'APE
GUAINA IMPERMEABILE
MASSETTO
TERRENO

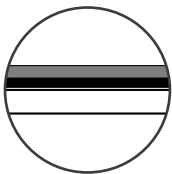
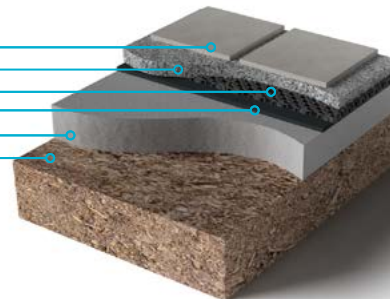

POSA SU MASSETTO CON COLLA

Installation Slabs On A Screed
Pose De Dalles C Ramiques Sur Chape
Anleitungen Für Die Verlegung Von Keramikplatten Auf Estrich

IDEA CERAMICA / Products / Prodotti / 20 mm
STUCCO
COLLA PER ESTERNI
STRATO DI IMPERMEABILIZZAZIONE
MASSETTO
CEMENTO RINFORZATO
TERRENO

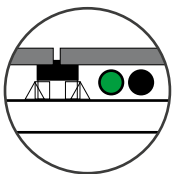
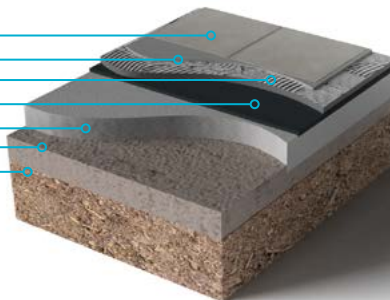

POSA SOPRAELEVATA

Instructions For Installation Of A Raised Floor For Exterior Locations
Instructions Pour La Pose D'un Plancher Sur Lev Pour Am Nagements Ext Rieurs
Verlegung Von Schwimmendem Bodenbelag Für Aussenbereichemikplatten Auf Estrich

IDEA CERAMICA / Products / Prodotti / 20 mm
SUPPORTO FISSO O REGOLABILE
MASSETTO

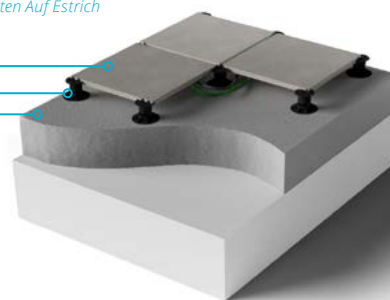

2cm | 60x60

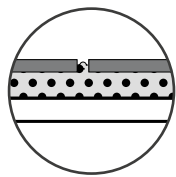

POSA SU GHIAIA

INSTALLED ON GRAVEL.
POSE SUR GRAVIER.

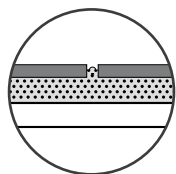

POSA SU SABBIA

INSTALLED ON SAND.
POSE SUR SABLE.



TORO 180°



30x60



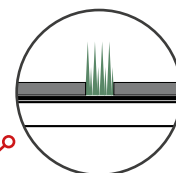

POSA SU ERBA

PLACED ON THE GROUND.
POSE À PAS JAPONAIS.

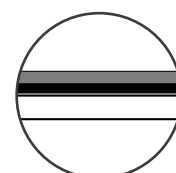

POSA SU MASSETTO CON COLLA

INSTALLTION USING
PROPER ADHESIVE
ON A SCREED BASE.
POSE TRADITIONELLE (COLLÉE).

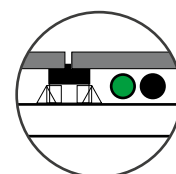

POSA SOPRAELEVATA

RAISED FLOOR BY
DEDICATED SUPPORT.
POSE SUR PLOTS.

GRES PORCELLANATO SPESSORE 2 CM
GLAZED PORCELAIN THICKNESS 2 CM
GRÈS CÉRAME EPAISSEUR 2 CM

TECH | INFO

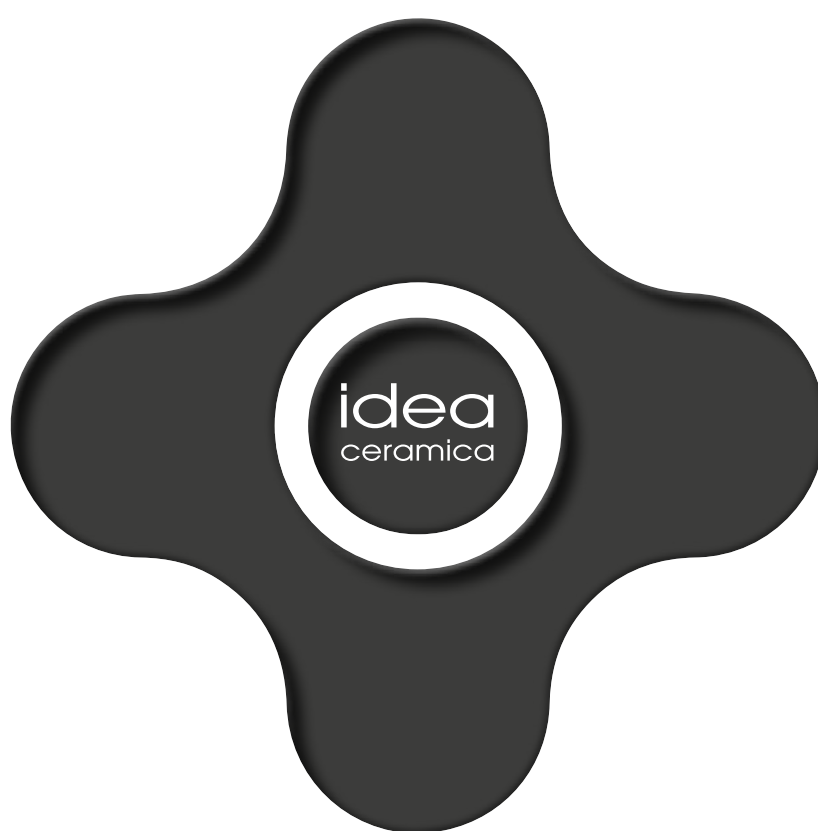

INFORMAZIONI GENERALI
GENERAL INFORMATION

CARATTERISTICHE TECNICHE

Technical features

Caractéristiques techniques

Technische Eigenschaften

PAVIMENTO

Floor tile

RIVESTIMENTO

Wall tile



	Metodo di prova Testing method Méthode d'essai Prüfmethode	Valori prescritti International Standard Internationale Normwerte Valeurs Prescrites	Valori prescritti International Standard Internationale Normwerte Valeurs Prescrites	Valori medi Average Value Mittelwert Valeurs Moyennes
Assorbimento d'acqua Water absorption Absorption d'eau Wasseraufnahme	ISO 10545 - 3	≤ 0,5 %	> 10 %	Conforme In accordance Entsprechend
Lunghezza e larghezza Length and width Longueur et largeur Länge und Breite	ISO 10545 - 2	+/- 0,6 %	+/- 0,5 %	Conforme In accordance Entsprechend
Spessore Thickness Épaisseur Stärke	ISO 10545 - 2	+/- 5 %	+/- 10 %	Conforme In accordance Entsprechend
Rettilineità degli spigoli Straightness Equerrage des angles Geradlinigkeit	ISO 10545 - 2	+/- 0,5 %	+/- 0,3 %	Conforme In accordance Entsprechend
Ortogonalità Rectangularity Orthogonalité Rechtwinkligkeit	ISO 10545 - 2	+/- 0,6 %	+/- 0,5 %	Conforme In accordance Entsprechend
Planarità Warpage Planéité Ebenflächigkeit	ISO 10545 - 2	+/- 0,5 %	+/- 0,5 % - 0,3%	Conforme In accordance Entsprechend
Coefficiente di attrito (scivolosità) Friction coefficient (slipperiness) Coefficient de friction (glissement) Reibungskoeffizient (Schlupfrigkeit)				
Coefficiente dilatazione termica lineare Coefficient of linear thermal-expansion Coefficient de dilatation thermique linéaire Lineare Wärmeausdehnung	ISO 10545 - 8	9 MK ¹		7 MK¹
Resistenza alla flessione Flexion resistance Résistance à la flexion Biegezugfestigkeit	ISO 10545 - 4	> 35 N/mm ²	> 15 N/mm ²	Conforme In accordance Entsprechend
Resistenza all'abrasione profonda Deep abrasion resistance Résistance à l'abrasion profonde Beständigkeit gegen Tiefenabrieb				
Resistenza al gelo Frost resistance Résistance au gel Frostwiderstandsfähigkeit	ISO 10545 - 12	Nessuna alterazione No alteration		Conforme In accordance Entsprechend
Resistenza agli sbalzi termici Thermal shock resistance Résistance aux écarts de température Temperaturwechselbeständigkeit	ISO 10545 - 9	Nessuna alterazione No alteration		Conforme In accordance Entsprechend
Resistenza dei colori alla luce Color resistance to light Résistance de la couleur à la lumière Lichtbeständigkeit	DIN 51094	Nessuna alterazione No alteration		Conforme In accordance Entsprechend
Resistenza ai prodotti chimici Chemical resistance Résistance aux produits chimiques Chemikalienfestigkeit	ISO 10545 - 13	Classe UB min	Classe GB min	Conforme In accordance Entsprechend
Resistenza alle macchie Stain resistance Résistance aux taches Flecken-Beständigkeit	ISO 10545 - 14	Classe 3 min	Classe 3 min	Conforme In accordance Entsprechend

UNI EN 14411 G
Gruppo BIa GL

UNI EN 14411 L
Gruppo BIII GL

Pavimenti in gres porcellanato
Porcelain wall and floor tiles

Rivestimenti in bicottura
Double firing wall tiles



CONDIZIONI GENERALI VENDITA

1) ACCETTAZIONE DA PARTE DELL'ACQUIRENTE DELLE CONDIZIONI GENERALI DI VENDITA DEL VENDITORE

Queste Condizioni Generali di Vendita saranno valide per ogni contratto della IDEA Ceramica ("Venditore") per la vendita di merci o articoli ("Prodotti") a qualsiasi persona che ha acquistato o concordato di acquistare prodotti dal Venditore ("Acquirente"), a meno che il Venditore abbia diversamente convenuto per iscritto. Al momento in cui inoltra un ordine dei Prodotti, l'Acquirente accetta queste Condizioni Generali di Vendita. Qualsiasi altro termine o condizione che possa essere predisposto in qualsiasi momento dall'Acquirente, sotto forma di ordine dell'Acquirente o in altro modo (sia in forma orale, dattiloscritta, scritta o stampata) sarà nullo e non valido e non avrà nessun effetto anche se non verrà sollevata un'esplicita obiezione allo stesso da parte del Venditore.

2) ACCETTAZIONE E CONFERMA DELL'ORDINE

Tutti gli ordini dell'Acquirente, ottenuti tramite un agente del Venditore o altrimenti, sono sottoposti all'approvazione del Venditore e possono essere accettati o modificati dal Venditore, in tutto o in parte. L'accettazione del Venditore di parte dell'ordine non costituisce accettazione di altra parte dell'ordine. Nessun ordine dell'Acquirente sarà vincolante per il Venditore, a meno che non sia accettato dal Venditore, presso la sede Commerciale del Venditore a Finale Emilia (MO) - Italy, sul modulo di Conferma d'Ordine del Venditore, firmato da un funzionario o impiegato del Venditore presso la sede centrale del Venditore, debitamente autorizzato firmare per conto del Venditore, e con i limiti stabiliti in tale Conferma d'Ordine. Qualsiasi termine, condizione o disposizione riportata nella Conferma d'Ordine del Venditore, al quale non viene sollevata obiezione da parte dell'Acquirente per iscritto entro dieci giorni dalla data della Conferma, si considera definitivamente accettato dall'Acquirente. La Conferma d'Ordine del Venditore sarà vincolante per quanto riguarda i Prodotti e le quantità vendute od ordinate. Qualsiasi ordine dell'Acquirente sarà vincolante per l'Acquirente a meno che è fino a quando non verrà rifiutato per iscritto dal Venditore e non può essere annullato, ritirato o modificato dall'Acquirente, tuttavia, nel caso di parziale accettazione da parte del Venditore, l'Acquirente non sarà più vincolato rispetto alle parti dell'ordine non accettate dal Venditore.

3) PREZZI

A meno che il Venditore non si sia accordato diversamente l'Acquirente pagherà al Venditore i Prodotti ai prezzi in vigore al momento della spedizione e tutti i prezzi quotati o fatturati dal Venditore sono per consegna franco fabbrica, con esclusione delle spese di trasporto e spese di spedizione, delle tasse, oneri e dazi doganali. I prezzi del Venditore possono, a discrezione del Venditore, essere aumentati, dopo l'accettazione da parte del Venditore dell'ordine dell'Acquirente, per riflettere eventuali aumenti dei materiali, della manodopera o altri costi del Venditore. Il Venditore notificherà all'Acquirente tale aumento di prezzo entro trenta giorni dalla data di tale aumento.

4) SCONTI ED ABBUONI

Salvo quanto esplicitamente riportato nella Conferma d'Ordine dal Venditore o quanto altrimenti concordato dal Venditore per iscritto, l'Acquirente non sarà autorizzato a ricevere alcuno sconto, abbuono, riduzione, conguaglio o commissione di alcun tipo, direttamente o indirettamente. Nessun agente del Venditore è autorizzato ad emettere o concedere tali sconti, abbuoni, riduzioni, conguagli o commissioni per conto del Venditore. Qualsiasi sconto concesso dal Venditore per il pagamento anticipato di qualsiasi fattura verrà concesso solamente se l'intero importo specificato nella fattura sarà ricevuto dal Venditore alla data di scadenza della fattura o prima di tale data.

5) TEMPI DI CONSEGNA

Qualsiasi data di consegna specificata dal Venditore verrà considerata approssimativa. In nessun caso il termine di consegna dei Prodotti potrà essere considerato decisivo. Il Venditore si riserva di cancellare, interamente o in parte, oppure di sospendere o ritardare, interamente o, in parte, qualsiasi ordine per i seguenti motivi: (I) ordine di quantità eccezionale rispetto alla quantità normale, (II) esigenze di produzione del Venditore o programmi di consegna; (III) carenze da parte dei fornitori del Venditore nella consegna di materiali; (IV) blocco del lavoro o altri problemi di manodopera; (V) ragioni di forza maggiore o (VI) qualsiasi altro evento al di fuori del controllo del Venditore. In conseguenza delle condizioni od eventi sopra specificati, le date di consegna saranno prorogate per un periodo di tempo pari al tempo aggiuntivo richiesto dal Venditore per effettuare la consegna. Il Venditore si riserva anche il diritto di cessare la produzione di particolari Prodotti o linee di Prodotti, oppure di sostituire altri Prodotti o linee, secondo la produzione e la domanda di mercato. L'Acquirente rinuncia a qualsiasi ed ogni rivendicazione per ritardi nella consegna dei Prodotti o mancata spedizione, derivanti dall'esercizio, da parte del Venditore, dei suoi diritti in base a queste Condizioni Generali di Vendita, ivi comprese, senza alcuna limitazione, pretese per danni diretti, indiretti, accidentali, consequenziali o altri danni o compensazioni, ed il diritto di terminare o annullare il Contratto, in tutto o in parte.

6) RISCHIO DELLA PERDITA

Indipendentemente da qualsiasi altra condizione di vendita (CIF, FOB, o altro) che possa venire indicata, ed indipendentemente dal fatto che le spese di trasporto o di spedizione vengano pagate dal Venditore: (I) tutti i rischi della perdita o danni ai Prodotti passeranno all'Acquirente al momento della consegna dei Prodotti da parte del Venditore ad un vettore; (II) qualsiasi accordo di spedizione preso dal Venditore con i vettori o gli agenti spedizionieri, su richiesta dell'Acquirente, sarà fatto unicamente per conto dell'Acquirente ed unicamente a spesa e rischio dell'Acquirente, (III) qualsiasi agente nominato per tali spedizioni sarà unicamente l'agente dell'Acquirente a tutti gli effetti; (IV) l'Acquirente sarà responsabile dello scarico e della consegna dei Prodotti a destinazione e (V) qualsiasi rivendicazione per perdite o danni sarà fatta dall'Acquirente solo nei confronti del vettore.

7) CONDIZIONI DI PAGAMENTO

a) L'Acquirente effettuerà il pagamento presso la Sede Commerciale del venditore a Finale Emilia (MO) - Italy, secondo quanto stabilito nel contratto. Il pagamento sarà effettuato dall'Acquirente indipendentemente da qualsiasi rivendicazione, ivi compresa, senza limitazione, qualsiasi rivendicazione per qualsiasi difetto occulto, carenza o irregolarità dei Prodotti. Salvo quanto altrimenti concordato specificatamente dal Venditore per iscritto, il pagamento da parte dell'Acquirente è dovuto al ricevimento della fattura del venditore nella valuta riportata in fattura. L'accettazione da parte del venditore di qualsiasi assegno, tratta, pagherò o altro metodo, non costituirà pagamento fino a quando il Venditore non avrà incassato l'intero importo in contanti. Nel Caso di qualsiasi ritardo nel pagamento, il Venditore avrà il diritto di sospendere le consegne e potrà, a sua scelta: (I) richiedere il pagamento immediato di tutto o di parte degli importi dovuti all'Acquirente, oppure pretendere garanzie per tale pagamento che risultino soddisfacenti per il Venditore, indipendentemente da qualsiasi condizione di credito concordata precedentemente, e (II) terminare il contratto (così come tutti gli altri contratti con l'Acquirente), interamente o in parte e ritenere responsabile l'Acquirente dei danni. Nel caso in cui il venditore non riceva alcun pagamento entro la data dovuta all'Acquirente dovrà pagare al Venditore, ad un tasso pari al 5% al di sopra del tasso ufficiale della Banca d'Italia durante tale periodo, oppure al tasso più alto ammesso per legge, a seconda di quale risulti inferiore. Il diritto del Venditore a tale interesse sarà da intendersi in aggiunta e non in sostituzione di tutti gli altri diritti e rimedi di cui potrà avvalersi il Venditore, in caso di mancato pagamento. Qualsiasi pagamento ricevuto dal Venditore potrà essere applicato al saldo dovuto dall'Acquirente al Venditore; nella maniera in cui il venditore, a sua sola discrezione, determinerà, malgrado eventuali istruzioni contrarie da parte dell'Acquirente.

b) Indipendentemente da qualsiasi diverso accordo riguardo ai pagamenti o condizioni di credito, il Venditore potrà, a propria discrezione, in qualsiasi momento e di volta in volta, richiedere il pagamento in contanti prima della spedizione di parte o di tutti i Prodotti, oppure richiedere il pagamento anticipato di qualsiasi o di tutti gli importi dovuti o che saranno dovuti secondo il Contratto. Se il Venditore ritiene in buona fede che l'Acquirente non possa effettuare i pagamenti dovuti in base al Contratto, il venditore può, a sua sola discrezione, annullare il Contratto, interamente o in parte, fermo restando che l'Acquirente è tenuto a pagare i Prodotti già spediti.



8) GARANZIE; VARIAZIONI DI COLORE, TONALITÀ O SFUMATURE

a) SALVO QUANTO ESPRESSAMENTE GARANTITO PER ISCRITTO, IL VENDITORE NON CONCEDE NESSUNA GARANZIA, ESPRESSA O IMPLICITA, RISPETTO AI PRODOTTI, IVI COMPRESA, SENZA LIMITAZIONE, QUALSIASI GARANZIA DI COMMERCIALIZZABILITÀ O ADEGUATEZZA AD UNO SCOPO PARTICOLARE. Inoltre qualsiasi garanzia scritta fatta dal venditore all'Acquirente relativamente a qualsiasi prodotto non vale per i prodotti in seconda o terza scelta, merce sfusa o merce in "stock".

b) L'Acquirente assume piena e completa responsabilità per verificare se i Prodotti sono conformi a quelli ordinati o sono adatti all'uso che vuole fare l'Acquirente, indipendentemente da qualsiasi suggerimento o istruzione dati dal Venditore, relativamente ai Prodotti o al loro uso. In nessun caso il Venditore potrà dare, o si consiederà avere dato, alcuna garanzia, espressa o implicita, relativamente alla corrispondenza o all'uniformità o a qualsiasi altro aspetto di colore, tonalità o sfumatura dei Prodotti, oppure relativamente alla conformità dei Prodotti al colore, alla sfumatura o alla tonalità di un qualsiasi campione. L'Acquirente riconosce che le variazioni di colore, sfumatura o tonalità sono caratteristiche dei Prodotti e sono ad essi intrinseche ed inevitabili, e che i campioni del Venditore sono solo approssimativi dei prodotti e che hanno solo lo scopo di fornire all'Acquirente un'idea generale dei Prodotti.

c) In particolare, e senza limitazioni, in nessun caso il Venditore concede o si ritiene abbia concesso alcuna garanzia, espressa o tacita, in relazione a dichiarazioni, descrizioni, illustrazioni contenute in qualsiasi opuscolo o in documentazione, oppure per avere fornito campioni di tali Prodotti.

9) RECLAMI

a) Qualsiasi reclamo per violazione delle garanzie o altri reclami di qualsiasi tipo da parte dell'Acquirente, ivi comprese, senza limitazioni, reclami per difetti palesi od occulti dei Prodotti, deve essere specifico e deve essere fatto per iscritto per lettera raccomandata con ricevuta di ritorno, spedita alla Sede Commerciale del Venditore a Finale Emilia (MO) - Italy, prima dell'installazione, dell'uso o dell'applicazione dei prodotti e, in ogni caso, non oltre otto giorni dalla data di ricevimento dei Prodotti relativamente ai quali viene fatta la denuncia. La mancata presentazione del reclamo nella maniera sopra indicata oppure entro tale termine costituirà un'accettazione irrevocabile dei Prodotti ed un'ammissione da parte dell'Acquirente che i Prodotti sono completamente rispondenti ai termini, le condizioni e le specificazioni del contratto, in nessun caso l'Acquirente potrà presentare reclami per Prodotti che sono già stati installati, utilizzati o applicati

b) Nel caso di inadempimento da parte del Venditore, il Venditore può a sua scelta, (I) sostituire i Prodotti interessati, oppure (II) annullare o terminare il Contratto, in tutto o in parte, senza obbligo di sostituzione della merce. L'Acquirente rinuncia a qualsiasi altra rivendicazione o diritto che potrebbe avere altrimenti in connessione con tale inadempimento, ivi compreso, senza limitazioni, rivendicazioni o diritti per danni diretti indiretti, accidentali, consequenziali, punitivi o altre compensazioni e il diritto di terminare od annullare il Contratto, in tutto o in parte.

c) L'Acquirente non può accettare solo una parte dei Prodotti consegnati. L'accettazione di una qualsiasi parte dei Prodotti costituirà accettazione di tutti i Prodotti, indipendentemente dal fatto che i Prodotti siano parte di una spedizione o di più spedizioni.

d) I Prodotti non possono essere restituiti dall'Acquirente senza una preventiva autorizzazione scritta da parte del Venditore. Tutte le restituzioni saranno soggette a verifica al loro arrivo nel punto specificato in tale autorizzazione scritta.

10) RISERVATO DOMINIO SULLA MERCE

Fino a quando il Venditore non avrà ottenuto il pagamento completo della merce da parte dell'Acquirente e qualsiasi altro importo dovuto dall'Acquirente al Venditore, il Venditore mantiene il diritto di proprietà sui Prodotti, secondo quanto disposto dall'articolo 1523 del Codice Civile Italiano.

11) SPESE DI RECUPERO DEI CREDITI

Nel caso in cui il Venditore intraprenda procedure per incassare qualsiasi importo dall'Acquirente, oppure per fare valere qualsiasi diritto sulla base del Contratto, incluso il riservato dominio, l'Acquirente dovrà rimborsare al Venditore tutte le spese, competenze ed onorari del giudizio.

12) DIRITTI DI PROPRIETÀ

Tutti i diritti relativi su modelli, disegni, nomi commerciali, marchi di fabbrica e copyright utilizzati per o in connessione con i Prodotti sono di proprietà e rimarranno di esclusiva proprietà del Venditore e l'Acquirente non avrà alcun diritto od interesse rispetto agli stessi. L'Acquirente si impegna a non utilizzare e/o riprodurre oppure fare in modo che qualcuno utilizzi e/o riproduca, sia direttamente o indirettamente modelli, disegni, nomi e marchi copyright.

13) TERMINI DI CONTRATTO

Il Venditore avrà il diritto di annullare o terminare il contratto, interamente o in parte, come segue: (I) entro centoventi giorni dalla data della Conferma d'Ordine del Venditore, a discrezione del Venditore, oppure (II) in qualsiasi momento, nel caso in cui il Venditore incontri difficoltà nell'ottenere forniture regolari o sufficienti di materiali. L'Acquirente rinuncia a qualsiasi ed ogni rivendicazione o diritto che potrebbe avere, ivi compresi, senza limitazione, ogni e qualsiasi rivendicazione o diritto a danni diretti, indiretti, accidentali, consequenziali, punitivi o altre compensazioni, derivanti dall'annullamento o termine, in tutto o in parte, del Contratto o di qualsiasi altro contratto tra Venditore ed Acquirente, oppure di altre clausole delle Condizioni Generali di Vendita.

14) LEGGE APPLICABILE

Il contratto sarà governato ed interpretato secondo la legge della Repubblica Italiana.

15) GIURISDIZIONE

Tutte le controversie derivanti da o in connessione con il Contratto o i Prodotti saranno decise a Modena.

16) MODIFICHE

Il contratto non può essere oralmente cambiato, modificato, emendato in tutto o in parte. Qualsiasi modifica, emendamento, cambiamento o cancellazione, per essere validi, devono essere apportati per iscritto, e firmati da un funzionario o impiegato del Venditore nella Sede Commerciale del Venditore a Finale Emilia (MO) - Italy, debitamente autorizzato a firmare per conto del Venditore.



GENERAL CONDITIONS OF SALE

1) BUYER'S ACCEPTANCE OF SELLER'S GENERAL CONDITIONS OF SALE

These General Conditions of Sale shall apply to every Contract of IDEA Ceramica ("Seller") for the sale of goods or articles ("Merchandise") to as person who has purchased or agreed to purchase Merchandise from Seller (the "Buyer"), unless Seller otherwise specifically agrees in writing By placing any order for Merchandise, the Buyer agrees to these General Conditions of Sale. Any other terms of conditions which may at any time be indicated by the Buyer's order from or otherwise (whether oral, typed, written or printed) shall be null and void and of no effect even if not expressly objected to by Seller.

2) ACCEPTANCE AND CONFIRMATION OF ORDER

All orders of the Buyer, whether taken by any agent of Seller at shows or otherwise, are subject to Seller's approval and may be accepted or modified by Seller, in whole or in part. A partial acceptance by Seller of any such order shall not constitute an acceptance of any other part of the order. No order of the Buyer will be binding upon Seller unless accepted by Seller at Seller's office in Finale Emilia (MO) - Italy on Seller's form of Order Confirmation, signed by an officer or employee of Seller at Seller's head office duly authorized to sign on behalf of Seller, and then only as and to the extent set forth in such Order Confirmation. Any term, condition or provision set forth in Seller's Order Confirmation which is not objected to by the Buyer in writing within ten days after the date thereof will conclusively be deemed to have been accepted by the Buyer. Seller's Order Confirmation shall be controlling regarding the Merchandise and quantities sold or required to be sold by Seller to the Buyer. Every order of the Buyer will be binding on the Buyer unless and until it is rejected in writing by Seller, and may not be cancelled, withdrawn or modified by the Buyer; however, in the event of a partial acceptance by Seller, the Buyer will no longer be bound with respect to the parts of the order not accepted by Seller.

3) PRICES

Unless otherwise specifically agreed by Seller in writing, the Buyer will pay the prices of Seller for the Merchandise in effect at the time of shipment and all prices quoted or invoiced by Seller are for delivery ex factory, excluding transportation and shipping charges, taxes, fees and customs duties. Seller's prices may, at Seller's option, be increased, after Seller's acceptance of the Buyer's order, to reflect any increases in Seller's materials, labor or other costs. Seller will notify the Buyer of any such price increase within thirty days from the date of such increase.

4) DISCOUNTS AND ALLOWANCES

Except as expressly provided in Seller's Order Confirmation or otherwise agreed by Seller in writing, the Buyer will not be entitled to any discount, allowance, rebate, settlement or commission or any kind, directly or indirectly. No agent of Seller is authorized to issue or agree to any such discount, allowance, rebate, settlement or commission on behalf of Seller. Any discount granted by Seller for prepayment of any invoice will be allowed only if the full amount specified in the invoice is received by Seller on or before the due date of the invoice.

5) TIME OF DELIVERY

Any delivery dates specified by Seller will be deemed to be estimates only. In no event is the time of delivery of the Merchandise of the essence. Seller reserves the right to cancel, in whole or in part, or to suspend or delay, in whole or in part, any orders due to (I) the unusually large size of an order (II) exigencies of Seller's production or delivery schedule (III) shortages of, or failures of Seller's suppliers to deliver, or delays of Seller's suppliers in delivering materials, (IV) work stoppages or other labor troubles, (V) acts of God or (VI) any event in the nature of force majeure or beyond Seller's control. Delivery dates will be extended by the amount of any additional time required by Seller to make delivery as a result of any such condition or event or any change in the Contract. Seller also reserves the right to discontinue particular Merchandise or lines of Merchandise, or to substitute other Merchandise or lines, in response to production and market requirements and demands. The Buyer waives any and all claims and rights which the Buyer might otherwise have arising out of or in connection with or relating to any delay in delivery of the Merchandise for any reason whatsoever or any failure of Seller to deliver by reason of the exercise by Seller of any of its rights pursuant to these General Conditions of Sale, including, without limitation, any and all claims for or rights to direct, indirect, incidental, consequential or other damages or compensation, and any and all rights to terminate or cancel the Contract, in whole or in part.

6) RISK OF LOSS

Irrespective of any C.I.F., F.O.B. or other terms of sale which may be specified, and irrespective of whether the transportation or shipping charges are paid by Seller: (I) all risk of loss or damage to the Merchandise shall pass to the Buyer upon delivery of the Merchandise by Seller to a carrier; (II) any shipping arrangements made by Seller with carriers or forwarding agents at the Buyer's request shall be made solely on the Buyer's behalf and at the Buyer's sole cost and risk; (III) any agent appointed for such shipment shall be solely the Buyer's agent for all purposes; (IV) the Buyer shall be responsible for all the unloading and receipt of the Merchandise at its destination; and (V) any claim for loss or damage shall be made by the Buyer solely against the carrier.

7) TERMS OF PAYMENT

(a) The Buyer shall make payment at Seller's office in Finale Emilia (MO), Italy in accordance with the provisions of the Contract. Payment shall be made by the Buyer notwithstanding any claim, including, without limitation, any claim for any alleged defect, fault or irregularity in the Merchandise. Unless otherwise specifically agreed by Seller in writing, payment by the Buyer is due upon receipt of Seller's invoice in the currency stated in the invoice. Acceptance by Seller of any check, draft, promissory note or other instrument will not constitute payment until Seller has collected the full amount in cash. In the event of any delay in payment, Seller shall have the right to suspend deliveries and may, at its option (I) require immediate payment of all or any part of any and all sums owed by the Buyer, or guarantees or security for such payment satisfactory to Seller, irrespective of any credit terms previously agreed to, and (II) terminate the Contract (as well as any and all other contracts with the Buyer), in whole or in part, and hold the Buyer liable for damages. In the event Seller does not receive any payment by the due date the Buyer shall pay to Seller interest on the unpaid amount, from the due date to the date payment is actually received by Seller, at a rate equal to five percent above the official rate of the Bank of Italy during such period or the highest rate permitted by law, whichever is less. Seller's right to such interest shall be in addition to, and not in lieu of, all other rights and remedies arising by reason of such nonpayment. Any payment received by Seller may be applied to any outstanding balance owed by the Buyer as Seller, in its sole discretion may determine, any instructions of the Buyer to the contrary notwithstanding.

(b) Irrespective of any payment or credit terms specified or agreed to by Seller. Seller may, in its sole discretion, at any time and from time to time, require payment in cash before shipment of any or all of the Merchandise, or require payment in advance of any or all amounts due or to become due under the Contract. If Seller believes in good faith that the Buyer's ability to make the payments required by the Contract is or may become impaired, Seller may, in its sole discretion, cancel or terminate the Contract, in whole or in part, the Buyer remaining liable to pay for any Merchandise already shipped.



8) WARRANTIES; COLOR, TONE AND SHADE VARIATIONS

(a) EXCEPT FOR SUCH EXPRESS WRITTEN WARRANTIES AS MAY BE MADE BY SELLER TO THE BUYER, SELLER MAKES NO WARRANTY OR REPRESENTATION, EXPRESS OR IMPLIED, WITH RESPECT TO THE MERCHANDISE, INCLUDING, WITHOUT LIMITATION, ANY WARRANTY OF MERCHANTABILITY OR FITNESS FOR ANY PARTICULAR PURPOSE. Moreover, any written warranty made by Seller to the Buyer with respect to any Merchandise applies only to export grade Merchandise and does not apply to any other Merchandise, including, without limitation, second or third quality Merchandise, bulk Merchandise or occasional stock.

(b) The Buyer takes full and complete responsibility for ascertaining whether the Merchandise meets the requirements of or is suitable for the Buyer's intended use, regardless of any suggestion or direction given by Seller with respect to the Merchandise or the use thereof. Under no circumstances does Seller make, or shall Seller be deemed to have made, any warranty or representation, express or implied, with respect to match or with respect to the uniformity or any other aspect of the color, tone or shade of the Merchandise, or with respect to the conformity of the Merchandise to the color, tone or shade of any sample. The Buyer acknowledges that variations in color, tone and shade are characteristics of the Merchandise and are inherent and unavoidable, and that Seller's samples are only approximations of the Merchandise and are only intended to give the Buyer a general idea of the Merchandise.

(c) In particular, and without limitation, under no circumstances does Seller make, or shall Seller be deemed to have made, any warranty or representation, express or implied, by reason of any statement, description or illustration in any brochure or other literature or by reason of having furnished a sample of any Merchandise.

9) CLAIMS

(a) Any breach of warranty or other claim by the Buyer of any and every kind, including, without limitation, claims for defects known or unknown, must be specific and must be made in a writing dispatched to seller, by registered air mail, to Seller's office in Finale Emilia (MO), Italy, return receipt requested, prior to the installation, use or application of the Merchandise and, in any event, not later than eight days from the date of receipt of the Merchandise with respect to which the claim is made. Failure to make any claim in such manner or within such time shall constitute an irrevocable acceptance of the Merchandise and an admission by the Buyer that the Merchandise fully complies with all the terms, conditions and specifications of the Contract. In no event may any claim be made by the Buyer for Merchandise which has already been installed, used or applied.

(b) In the event of any breach of any warranty or any other obligation of Seller, Seller may, at its election, either (i) replace the Merchandise affected or (ii) cancel or terminate the Contract, in whole or in part, without any obligation to replace any Merchandise. The Buyer waives any and all other claims and rights which the Buyer might otherwise have arising out of or in connection with or relating to any and all such breaches, including, without limitation, any and all claims for or rights to direct, indirect, incidental, consequential, punitive or other compensation or damages, and any and all rights to terminate or cancel the Contract, in whole or in part.

(c) The Buyer may not accept only a part of the Merchandise delivered. Acceptance of any part of the Merchandise shall constitute acceptance of all of the Merchandise, whether or not the Merchandise is all tendered in one shipment.

(d) No Merchandise may be returned by the Buyer without the prior written authorization of Seller. All returns shall be subject to verification on arrival at the location specified, in such written authorization, for the return of the Merchandise.

10) TITLE TO AND SECURITY INTEREST IN MERCHANDISE

Until Seller collect in full all amounts required to be paid by the Buyer for the Merchandise, as well as any and all other amounts owed by the Buyer to Seller, Seller retains title to the Merchandise, in accordance with article 1523 of the Italian Civil Code, and Seller shall have a security interest in the Merchandise, under the Uniform Commercial Code as in effect in the United States, to secure the payment of all such amounts. By placing an order with Seller, the Buyer appoints Seller as its attorney-in-fact to sign and file any and all financing statements with respect to such security interest which Seller may deem necessary or desirable, or to file such financing statements without signature of the Buyer to the extent permitted by law. The Buyer shall, at the request of Seller, execute any and all financing statements and other documents which the Seller may request to perfect or evidence such title and such security interest.

11) COSTS OF COLLECTION

In the event Seller institutes proceedings to collect any amount owed by the Buyer, or to enforce any right under the Contract, including enforcement of any security interest granted to Seller, the Buyer shall reimburse Seller for all costs incurred in such legal proceedings, including reasonable attorneys' fees.

12) PROPRIETARY RIGHTS

All rights in designs, trade names, trademarks and copyrights of Seller used on or in connection with the Merchandise are proprietary and shall remain the exclusive property of Seller, and the Buyer shall have no right or interest therein or with respect thereto. The Buyer shall not reproduce or simulate, or cause or allow anyone to reproduce or simulate, either directly or indirectly, any such design, trade name, trademark or copyright.

13) TERMINATION OF THE CONTRACT

Seller shall have the right to cancel or terminate the Contract, in whole or in part, (i) within one hundred twenty days from the date of Seller's Order Confirmation, in Seller's sole discretion, or (ii) at any time, in the event Seller experiences difficulties in obtaining regular or sufficient supplies of or rights to direct, indirect, incidental, consequential, punitive or other damages or compensation, arising out of or in connection with or relating to any cancellation or termination, in whole or in part, pursuant to this or any other paragraph of these General Conditions of Sale, of the Contract or any other contract between Seller and the Buyer.

14) APPLICABLE LAW

The contract shall be governed by and construed in accordance with the law of the Republic of Italy, without giving effect to conflict of laws principles, except that the rights of Seller pursuant to its security interest in the Merchandise shall be governed by and construed in accordance with the Uniform Commercial Code as in effect in United States.

15) JURISDICTION 16) MODIFICATIONS

The Contract cannot be orally changed, modified, amended or discharged, in whole or in part. Any change, modification, amendment or discharge, to effective, must be in writing, signed by officer or employee of Seller at Seller's head office in Finale Emilia (MO) - Italy, duly authorized to sign on behalf of Seller.



CONSIGLI DI POSA E MANUTENZIONE

POSA IN OPERA

Prima di iniziare le operazioni di posa di una qualsiasi superficie si raccomanda di accertarsi che la partita di materiale sia adeguata e sufficiente per quantità, tono e calibro, a quella necessaria. Si dovranno poi seguire tutte le norme e le precauzioni che sono alla base di una corretta esecuzione del lavoro (preparazione del sottofondo, composizione della malta o dei collanti, rispetto dei tempi di essiccazione, posizionamento dei giunti di dilatazione, battitura, ecc. ...)

POSA CON ADESIVI

La posa deve essere effettuata da personale qualificato con l'ausilio di attrezzi adeguati. La superficie su cui si effettua la posa (massetto) deve essere perfettamente piana. Valore massimo consigliato non superiore a 3mm. per un dislivello determinato sotto un regolo di 2m. La superficie su cui si effettua la posa deve essere ben stagionata, priva di polvere e di fessurazioni visibili. Durante l'operazione di posa è vivamente consigliato l'utilizzo di un'adeguata illuminazione.

La scelta dell'adesivo è condizionata dalla tipologia delle piastrelle (gruppo di appartenenza e formato), dal tipo di superficie da rivestire e dalla sua destinazione d'uso. E' opportuno verificare la posa del materiale prima che il collante sia secco, per facilitare eventuali correzioni.

POSA CON MALTA FRESCA

La posa a malta cementizia fresca o "strato spesso" è sconsigliata per formati aventi lato > 30 cm e con supporti non assorbenti.

REALIZZAZIONE DEI GIUNTI

I giunti sono elementi molto importanti per il mantenimento di una buona superficie piastrellata e si consiglia di avvalersi della collaborazione e/o consulenza di un posatore professionista. Si declina ogni responsabilità per la posa senza fuga; si considera posa a "giunto minimo" quella con fuga a 2 mm.

I giunti devono essere posizionati:

- su raccordi strutturali (giunti strutturali)
- tra suolo e parete (giunti perimetrali)
- tra una piastrella e l'altra (giunti di posa o fuga)
- tra piastrelle ed altri materiali (es. accostamento ceramica / linoleum / legno)

STUCCATURA SUPERFICIE POSATA

Prima di realizzare le fughe è consigliabile attendere fino a completa asciugatura del collante e assicurarsi che i giunti di posa siano vuoti e liberi da ogni traccia di collante e/o polveri. Stuccare piccole superfici per volta (4-5 mq). Questo è da tenere in particolare considerazione per prodotti strutturati, antiscivolo e levigati. Eliminare l'eccesso di fugante dalla superficie con movimenti diagonali quando il prodotto è ancora umido e togliere tutti i residui, in particolar modo per le superfici da esterno. Pulire accuratamente con una spugna bagnata in acqua limpida e pulita e ripassare con straccio umido su tutta la superficie fughe comprese. Per fughe in netto contrasto cromatico con le piastrelle posate è consigliabile testare il fugante su un' area circoscritta e nascosta. Per gli stucchi epossidici si raccomanda la pulizia con spugna e abbondante acqua. La velocità di reazione e indurimento di questi prodotti rende impossibile la rimozione dei residui successivamente all'indurimento. Il giorno dopo la stuccatura effettuare una pulizia completa con detergente alcalino. Si consiglia di consultare i produttori di materiale fugante per verificare la scelta corretta della fuga rispetto al tipo di piastrella.

PULIZIA E MANUTENZIONE DOPO LA POSA

Un cantiere si può considerare completamente finito quando è sgombro da qualunque utensile/materiale derivante dalle lavorazioni. Per ridurre i rischi di danneggiamento della superficie piastrellata, è necessario proteggerla ed evitare il più possibile la presenza di materiali abrasivi (polveri o residui da lavorazioni successive).

PULIZIA INIZIALE

Il lavaggio dopo la posa è un'una fase di fondamentale importanza per tutti gli interventi successivi e per una corretta manutenzione. Un accurato lavaggio iniziale permette ai pavimenti di restare belli e protetti a lungo e si esegue normalmente una sola volta prima dell'utilizzo del pavimento. Si raccomanda di effettuare la pulizia iniziale dopo 4-5 giorni e non più tardi di 10, dalla posa e stuccatura della superficie. La superficie fugata e pulita può presentare un film di residui cementizi che non sono asportabili con sola acqua per cui si rende necessario l'utilizzo di un prodotto a base acida, opportunamente diluito (diluizione da 1:10 a 1:4 in acqua fredda), in base a quanto dichiarato dal produttore. La prima operazione da eseguire è quella di bagnare la superficie piastrellata ed in particolare le fughe (di norma non resistenti agli acidi). Spargere la soluzione acida preparata e lasciare agire per un breve tempo (2 min). Non lasciare asciugare il prodotto applicato. Procedere alla rimozione della soluzione aiutandosi con una macchina mono spazzola (disco non abrasivo), aspira liquidi, altri mezzi e/o manualmente e alla fine risciacquare abbondantemente. E' importante sottolineare che la pulizia eseguita con macchine (particolarmente consigliata per prodotti strutturati e per grandi superfici), va sempre completata manualmente nei punti difficilmente raggiungibili, soprattutto negli angoli, lungo le pareti dei locali ~ in ogni zona in cui la mono spazzola non può operare. E' sempre consigliabile testare la resistenza del prodotto agli acidi su un pezzo non posato o su una piccola porzione nascosta della superficie piastrellata; in particolare per prodotti lappati o levigati. L'uso di prodotti di pulizia contenenti acido fluoridrico (HF) e suoi derivati sono da evitare.

PULIZIA ORDINARIA

Gli interventi di pulizia ordinaria delle superfici hanno lo scopo di rimuovere lo sporco, cancellare i segni e ripristinare l'aspetto originale. Le piastrelle in gres porcellanato smaltato non necessitano di trattamenti di protezione e una corretta e sistematica pulizia è sufficiente a mantenere inalterata la superficie. Un'accurata pulizia deve essere fatta con un normale lavaggio con acqua calda, straccio / spugna morbida ed eventualmente con l'utilizzo di detergenti neutri. Per locali con grandi superfici possono essere utilizzate macchine industriali lavasciuga con completamento manuale dove necessario.

RACCOMANDAZIONI:

- evitare di strofinare le superfici con strumenti abrasivi, come pagliette in metallo o spazzole dure, che potrebbero lasciare graffi e segni indelebili;
- rimuovere eventuali residui grassi o oleosi con detergenti contenenti solventi organici o con detergenti alcalini (pH>9) e fare seguire un accurato risciacquo;
- evitare l'utilizzo di saponi in quanto tendono a lasciare uno strato viscido, in particolare se utilizzati in abbinamento ad acque dure;
- non utilizzare prodotti contenenti cere o brillantanti;
- evitare l'uso di detergenti abrasivi su superfici lucide e/o levigate; possono essere utilizzati su materiali matt., previa verifica su una piccola porzione piastrellata.

In generale l'uso di qualunque detergente non neutro, deve essere preliminarmente testato su una piastrella non posata o su una porzione nascosta della pavimentazione.

Consigli di Posa



ADVICE FOR LAYING AND MAINTENANCE

LAYING

Before laying on any surface, make sure that the material is appropriate and sufficient in terms of quantity, shade and work-size to suit the laying needs. All regulations and precautions concerning the correct execution of the works must be followed (preparing the bed, grout or adhesive composition, respect for drying times, position of the expansion joints, beating, etc. ...)

LAYING WITH ADHESIVES

Laying must be done by qualified staff using appropriate equipment. The surface to be laid (screed) must be perfectly leveled. Maximum recommended value no more than 3mm for an uneven surface measured with a 2m ruler. The surface to be laid must be well seasoned, dust-free and with no visible cracks. During laying the use of appropriate lighting is strongly recommended. The choice of adhesive depends on the type of tile (type and size), the type of surface laid on and the type of foreseen use. Check that the tiles are laid correctly before the adhesive dries in order to facilitate any required corrections.

LAYING WITH FRESH MORTAR

Laying with fresh cement-based mortar or "thick layers" is not recommended for sizes more than 30 cm long and with non-absorbent supports

JOINTS

Joints are very important elements for maintaining a good tiled surface, it is recommended to make use of the collaboration and/or advice of a professional layer, The company declines all responsibility for laying without joints; minimum joint laying has a gap of 2 mm.

The joints must be positioned:

- on structural joints;
- between the floor and the wall (perimeter joints);
- between one tile and another (laying joints);
- between the tiles and other materials (e.g. combinations of ceramics / linoleum / wood).

GROUTING LAID SURFACES

Before grouting wait for the adhesive to dry completely and make sure that the laying joints are empty and free of all traces of adhesive and/or dust. Grout small areas at a time (4-5 m²). This is particularly important for structured products, non-slip and polished surfaces. Remove excess grout from the tiles using diagonal movements when the product is still damp and remove all residues, particularly for external surfaces. Clean carefully using a sponge dampened in clean, limpid water and go over the whole surface, including the gaps, with a damp cloth. For grouting which has a strong colour contrast to the laid tiles, test the grout on a small, hidden area. When using epoxy grouts, clean with a sponge and plenty of water. The reaction and hardening times of these products make it impossible to remove any residues once they have hardened. The day after grouting, completely clean the surface with an alkaline detergent. Consult the grout manufacturers to verify the correct choice of grout for the type of tile.

CLEANING AND MAINTENANCE AFTER LAYING

Worksites are deemed to be completely finished once they have been cleared of all tools and materials used during the operations. To reduce the risk of damaging tiled surfaces, protect them and avoid the presence of abrasive materials (dust and residues from operations carried out after laying) as far as possible.

INITIAL CLEANING

Washing after laying is of fundamental importance to all operations carried out afterwards and to assure correct maintenance. Careful initial cleaning keeps floors beautiful and protected longer and is done once only before using the floor. Initial cleaning should be carried out 4-5 days after laying, and in any case no longer than 10 days after laying and grouting. The grouted and cleaned surface may have a concrete film which cannot be removed using water alone, and therefore an acid-based product, suitably diluted (from 1:10 to 1:4 in cold water) should be used, following the manufacturer's instructions. The first operation is to wet the tiled surface and particularly the gaps (grout is not usually acid-resistant). Spread the prepared acid solution and leave for a short time (2 minutes). Do not allow the applied product to dry. Remove the solution using a brushing machine (with a non-abrasive disk), wet vac or other means and/or manually, then rinse well. It should be remembered that machine cleaning (which is particularly recommended for textured products and large surfaces) must always be completed by hand in tight corners, along walls and any spaces that the brushing machine cannot easily reach. It is always advisable to test the resistance of the product to acids on an unlaid tile or a small hidden surface; particularly for lapped or polished products. It is not recommended to use cleaning products containing hydrofluoric acid (HF) or its derivatives.

ORDINARY CLEANING

Ordinary cleaning removes dirt and marks and restores the surface to its original appearance. Porcelain stoneware tiles do not require protective treatment, and a thorough, systematic clean is sufficient to maintain the surface. Careful cleaning must be done by washing normally using hot water, a cloth or soft sponge and, if required, neutral detergents. For large areas, industrial washing machines can be used, with completion by hand where required.

RECOMMENDATIONS:

- Do not rub the surfaces using abrasive tools, such as metallic sponges or hard brushes, which could scratch them or leave indelible marks;
 - Grease and oil residues can be removed using detergents containing organic or alkaline solvents (pH>9) followed by careful rinsing;
 - Avoid the use of soap as this tends to leave a slimy layer, particularly when used with hard water;
 - Do not use products containing wax or shining agents;
 - Avoid the use of abrasive detergents on shiny and/or polished surfaces; they may be used on matt materials, checking first on 'a small hidden tiled area.
- Generally speaking, when using any non-neutral detergent, check first on an unlaid tile or a small hidden portion of the floor.



CONSEILS POUR LA POSE ET L'ENTRETIEN

POSE

Avant de commencer les opérations de pose d'une surface quelle qu'elle soit, il est recommandé de veiller à ce que le matériel soit adapté et de quantité suffisante, que la nuance et le calibre correspondent aux besoins. Il faudra ensuite se conformer à toutes les normes et prendre toutes les précautions qui sont à la base d'une bonne exécution du travail (préparation de la sous-couche, composition du mortier ou des colles, temps de séchage, mise en place des joints de dilatation, battage de la colle, double encollage à partir d'une certaine superficie de carreau, etc.)

POSE AVEC DES COLLES

La pose doit être effectuée par personnel qualifié qui se servira d'outils appropriés. La surface sur laquelle la pose est effectuée (chape) doit être parfaitement plane. Valeur maximum conseillée: max 3 mm pour une dénivellation au-dessous d'une règle de 2m. La surface sur laquelle le matériel est posé doit être parfaitement sèche, sans poussière ni fissurations visibles. Au cours de la pose, un bon éclairage est vivement conseillé. La colle sera choisie en fonction de la typologie des carreaux (catégorie et format), du type de surface à revêtir et du domaine d'application auquel les carreaux sont destinés. Il convient de vérifier la manière dont le matériel est posé avant que la colle ne soit sèche, afin de pouvoir effectuer plus facilement des corrections si nécessaire.

POSE AVEC MORTIER FRAIS

La pose avec du mortier à base de ciment frais ou par "couche épaisse" est déconseillée pour des formats ayant un côté >30 cm et avec des supports non absorbants.

RÉALISATION DES JOINTS

Les joints sont des éléments très importants pour qu'une surface carrelée se maintienne bien. C'est une phase pour laquelle il est conseillé de demander la collaboration et les conseils d'un carreleur professionnel. La responsabilité du fabricant ne pourra pas être mise en cause en cas de pose sans joints. On appelle "pose à joint minimum" une pose avec un joint de 2 mm.

Les joints doivent être positionnés:

sur des raccords structurels : joints de dilatation

entre sol et mur : joints périmétraux

entre deux carreaux : joints de pose ou jointement

entre des carreaux et d'autres matériaux : joints de juxtaposition céramique/ lino/ bois

JOINTOIEMENT DES SURFACES POSÉES

Avant de procéder au jointoiment, il est conseillé d'attendre que la colle soit bien sèche et de s'assurer que les joints de pose soient vides et libres de toute trace de colle et/ou de poussières. Jointer le carrelage en procédant par petites surfaces (4-5 m²). Ce conseil doit surtout être suivi pour des produits structurés, anti-dérapants et polis. Éliminer de la surface, le surplus de barbotine de jointoiment, en effectuant des mouvements en diagonale quand le produit est encore humide. Enlever toutes les traces excédentaires de joint, surtout pour les surfaces posées à l'extérieur. Nettoyer soigneusement avec une éponge imbibée d'eau claire et propre et repasser avec un chiffon humide sur toute la surface, joints compris. En présence de joint de couleur très contrasté avec la couleur des carreaux posés, il est conseillé de tester la barbotine de jointoiment sur une petite surface dissimulée. Pour les joints époxy, il est recommandé de nettoyer à grande eau avec une éponge. La vitesse de réaction et de durcissement de ces produits empêche l'élimination des excédents après qu'ils aient durci. Le lendemain du jointoiment, effectuer un nettoyage complet avec un nettoyant alcalin. Il est conseillé de consulter la préconisation des fabricants de joints pour vérifier si le choix effectué est correct par rapport au type de carreau.

NETTOYAGE ET ENTRETIEN APRÈS LA POSE

Un chantier peut être considéré comme entièrement fini quand il est débarrassé de tous les outils et de tout le matériel ayant servi à sa réalisation. Pour réduire les risques d'endommager la surface carrelée, il est nécessaire de la protéger et d'éviter le plus possible la présence de matières abrasives (poussières ou résidus laissés par les travaux effectués successivement).

NETTOYAGE INITIAL

Le lavage après la pose est une opération d'une extrême importance pour toutes les opérations qui s'ensuivront et pour pouvoir effectuer un entretien correct au quotidien. Bien nettoyer le carrelage au départ permet aux sols de garder longtemps leur beauté et d'être protégé à long terme. Généralement, ce nettoyage est effectué une seule fois avant d'utiliser le sol. Il est recommandé d'effectuer le nettoyage initial après 4 ou 5 jours (pas plus de 10) après la pose et le jointoiment. La surface jointoyée et nettoyée peut présenter un voile de ciment qui ne peut pas être éliminé à l'eau. Il est donc nécessaire d'utiliser un produit à base acide, correctement dilué (dilution de 1:10 à 1:4 dans l'eau froide), en fonction des conseils d'utilisation donnés par le fabricant. La première opération à exécuter est de mouiller la surface carrelée et en particulier les joints (qui généralement ne résistent pas aux acides). Répandre la solution acide préparée et laisser agir environ 2 minutes. Ne pas laisser sécher le produit appliqué. Procéder à l'élimination de la solution avec une laveuse monobrosse (disque non abrasif), aspirateur de liquides, autres appareils ou à la main. Rincer à grande eau à la fin. Soulignons que le nettoyage effectué avec des appareils (particulièrement conseillé pour des produits structurés et pour de grandes surfaces), doit toujours être parachévé par une intervention manuelle aux endroits difficiles à atteindre, c'est-à-dire dans les coins, le long des murs et partout où la monobrosse ne peut pas passer. Il est toujours conseillé de vérifier la résistance du produit aux acides en les testant sur un carreau non posé ou sur un endroit peu en vue d'un carreau de la surface déjà posé, surtout pour les produits semi-polis ou polis. L'utilisation de nettoyeurs contenant de l'acide fluorhydrique (HF) et de ses dérivés doit être évitée.

ENTRETIEN COURANT

Les opérations d'entretien courant des surfaces ont pour but d'éliminer la saleté, d'effacer les traces et de rendre au carrelage son aspect premier. Les carreaux en grès cérame émaillé n'ont pas besoin d'être traités pour être protégés. Un nettoyage correct et systématique suffit à préserver la beauté de leur surface. Un nettoyage soigné doit être fait par un lavage normal avec de l'eau chaude, une serpillière/éponge douce et éventuellement avec un nettoyant neutre. Pour les locaux recouverts de grandes surfaces, une machine industrielle lavante/séchante peut être utilisée. Finir par un lavage à la main là où cela s'avère nécessaire.

RECOMMANDATIONS:

éviter de frotter les surfaces avec des instruments abrasifs tels que les pailles de fer ou les brosses dures, qui pourraient laisser des rayures et des traces indélébiles;

éliminer toutes traces de graisse ou d'huile éventuellement présente au moyen de nettoyeurs contenant des solvants organiques, ou avec des nettoyeurs alcalins (pH>9) et terminer en rinçant soigneusement;

éviter d'utiliser des savons car ils ont tendance à laisser un film visqueux, surtout s'ils sont utilisés avec des eaux dures;

ne pas utiliser de produits contenant des cires ou des lustrants ;

éviter d'utiliser des nettoyeurs décapants sur des surfaces lustrées et ou polies; ils peuvent être utilisés sur des matériaux mats, après les avoir testés sur une petite surface carrelée : En général, l'utilisation de tout nettoyant non neutre doit être testée au préalable sur un carreau non posé ou sur une portion peu en vue du sol.

Conseils pour la Pose et l'entretien



VERLEGUNGS-UND PFLEGEHINWEISE

BAUSEITIGE VERLEGUNG

Bevor Sie mit der Verlegung der Fliesen beginnen, stellen Sie sicher, dass die Materialpartie im Hinblick auf Menge, Farbton und Größenklasse die Anforderungen erfüllt und ausreicht. Es müssen außerdem alle Normen und Vorsichtsmaßnahmen eingehalten werden, die die Grundlage für eine korrekte Ausführung der Arbeiten darstellen (Vorbereitung des Untergrunds, Zusammensetzung des Mörtels oder der Kleber, Trocknungszeiten, Lage der Dehnungsfugen, Anklopfen usw....)

VERLEGUNG MIT KLEBER

Die Verlegung muss durch qualifiziertes Personal mit geeigneten Werkzeugen durchgeführt werden. Die Fläche, auf der die Verlegung erfolgt (Estrich) muss perfekt eben sein.

Empfohlener maximaler Wert der Abweichung nicht über 3 mm beim Anlegen eines 2m-langen Richtscheits. Die Fläche, auf der die Verlegung erfolgen soll, muss vollständig trocken und frei von Staub und sichtbaren Rissen sein. Während der Verlegung wird dringend empfohlen, eine ausreichende Beleuchtung zu gewährleisten. Die Wahl des Klebers hängt von der Art der Fliesen (Gruppe und Größe), von der Art der Oberfläche, auf der verlegt werden soll und vom Bestimmungszweck ab. Die Verlegung der Fliesen sollte überprüft werden, bevor der Kleber trocken ist, um Korrekturen zu ermöglichen.

VERLEGUNG MIT FRISCHEM MÖRTEL

Die Verlegung mit frischem Zementmörtel oder "Dickbettverlegung" wird für Formate empfohlen, deren Seitenmaße größer als 30 cm sind und die auf nicht absorbierenden Untergründen verlegt werden sollen

DIE VERFUGUNG

Die Fugen sind für den Erhalt einer guten Fliesenoberfläche sehr wichtig und wir empfehlen, dafür die Arbeit bzw. Beratung eines Fachmanns in Anspruch zu nehmen. Wir übernehmen keine Haftung für eine fugenlose Verlegung, unter einer Verlegung mit sehr schmalen Fugen versteht man die Verlegung von 2 mm breiten Fugen.

Die Fugen müssen positioniert werden:

- an strukturellen Anschlüssen (Strukturfugen)
- zwischen Boden und Wand (Randfugen)
- zwischen einer Fliese und der anderen (Verlegefugen oder Fugen)
- zwischen Fliesen und anderen Materialien (z.B. Kombination von Keramik/ Linoleum/ Holz).

VERFUGEN VERLEGTER OBERFLÄCHEN

Bevor die Fugen ausgeführt werden, wird empfohlen, zu warten, bis der Kleber komplett trocken ist. Stellen Sie sicher, dass die Verlegefugen leer und frei von jeglichen Spuren von Klebstoff und/oder Staub sind. Verfugen Sie jeweils kleine Flächen (4 - 5m²). Dies gilt vor allem für strukturiert rutschfeste und polierte Fliesen. Entfernen Sie die überschüssige Fugenmasse mit diagonalen Bewegungen von der Oberfläche aus, wenn das Produkt noch feucht ist und entfernen Sie, vor allem in Außenbereichen, alle Rückstände. Gründlich mit einem Schwamm, der in reinem und klarem Wasser befeuchtet wurde, reinigen und mit einem feuchten Tuch über die gesamte Fläche einschließlich der Fugen nachwischen. Für Fugen, die im eindeutigen Farbkontrast zu den verlegten Fliesen stehen, sollten Sie die Fugenmasse an einer begrenzten, verdeckten Fläche vorher testen. Für Epoxid-Fugenmörtel wird die Reinigung mit einem Schwamm und sauberem Wasser empfohlen. Die schnelle Reaktion und das schnelle Härten dieser Produkte macht die Beseitigung von Rückständen nach dem Aushärten unmöglich. Am Tag nach der Verfugung ist eine gründliche Reinigung mit alkalischen Reinigungsmitteln erforderlich. Für die jeweilige Wahl der Fuge für die jeweilige Fliese wenden Sie sich bitte an den Hersteller des Fugenmittels.

REINIGUNG UND PFLEGE NACH DER VERLEGUNG

Eine Baustelle ist erst vollständig beendet, wenn sie frei von jedem Arbeitsmaterial ist. Um die Gefahr der Beschädigung der Fliesenoberfläche zu senken, ist es notwendig, sie zu schützen und so weit wie möglich die Anwesenheit von abrasiven Materialien (Pulver oder Rückstände der weiteren Verarbeitung) zu vermeiden.

GRUNDREINIGUNG

Die Grundreinigung nach der Verlegung ist wichtig, um die spätere Reinigung und Pflege zu ermöglichen. Eine sorgfältige Grundreinigung sorgt dafür, dass die Böden lange schön und geschützt bleiben. Sie wird normalerweise nur einmal vor der Benutzung des Bodens ausgeführt. Es wird empfohlen, die Erstreinigung nach 4-5 Tagen, spätestens aber nach 10 Tagen ab dem Verlegen und Verfugen der Oberfläche durchzuführen. Die verfugte und gereinigte Oberfläche kann einen Zementschleier aufweisen, der aber leicht nur mit Wasser entfernt werden kann. Dafür ist ein Reinigungsmittel auf Säurebasis erforderlich, das je nach den Anweisungen des Herstellers entsprechend verdünnt (Verdünnung von 1:10 bis 1:4 mit kaltem Wasser). Zuerst muss die geflieste Fläche mit Wasser gespült werden, dies gilt vor allem für die Fugen (die normalerweise nicht säurebeständig sind). Verteilen Sie die vorbereitete säurehaltige Lösung auf der Oberfläche und lassen Sie diese kurz einwirken (2 Minuten). Lassen Sie das aufgebrachte Mittel nicht eintrocknen. Entfernen Sie dann die Lösung mit einer Einbürstemaschine (nichtscheuernde Scheibe), einem Flüssigkeitssauger oder einem anderen Gerät, und/oder spülen Sie mit reichlich klarem Wasser nach. Es muss darauf hingewiesen werden, dass die maschinelle Reinigung einer Oberfläche (die besonders für strukturierte und große Oberflächen empfohlen wird) an den schwierig zu erreichenden Stellen stets eine manuelle Nachreinigung erforderlich macht, vor allem in den Ecken, entlang der Wände und in allen Bereichen, die von der Einbürstemaschine nicht erreicht werden. Es ist immer ratsam, die Haltbarkeit des Produktes gegen Säuren auf einer noch nicht verlegten Fliese oder in einem versteckten Bereich der bereits verfliesen Oberfläche zu testen, dies gilt insbesondere für geläppte oder polierte Fliesen. Die Verwendung von Reinigungsmitteln mit Flusssäure (HF) und seinen Derivate ist zu vermeiden.

GEWÖHNLICHE REINIGUNG UND PFLEGE

Die gewöhnliche Reinigung der Oberflächen dient der Entfernung von Schmutz, Spuren und Abdrücken. Sie hat das Ziel, das ursprüngliche Aussehen wieder herzustellen. Glasierte Feinsteinzeugfliesen benötigen keine Schutzbehandlung und die korrekte und systematische Reinigung ist ausreichend, um die Oberfläche dauerhaft schön zu halten. Eine gründliche Reinigung sollte mit warmem Wasser, einem Lappen oder weichen Schwamm und eventuell mit neutralen Reinigungsmitteln erfolgen. Für Räume mit großen Flächen können industrielle Reinigungsmaschinen verwendet werden, ggf. mit manueller Nachreinigung.

EMPFEHLUNGEN:

- Vermeiden Sie es, die Oberflächen mit Schleifmitteln, wie Scheuerschwämmen oder harten Bürsten zu reinigen, das kann zu Kratzern und Spuren führen, die sich nicht mehr entfernen lassen.
- Entfernen Sie eventuell verbleibende Fett- oder Ölrückstände mit Reinigungsmitteln, die organische Lösemittel enthalten, oder alkalischen Reinigungsmitteln (pH > 9) und spülen Sie dann gründlich nach. Avoid the use of soap as this tends to leave a slimy layer, particularly when used with hard water;
- Vermeiden Sie Seifen, da sie dazu neigen, eine schmierige Schicht zu hinterlassen, besonders wenn sie in Verbindung mit hartem Wasser verwendet werden;
- Verwenden Sie keine Produkte mit Wachs oder Glanzzusätzen.
- Vermeiden Sie Scheuermittel auf polierten oder glänzenden Oberflächen. Sie können auf jedoch matten Materialien verwendet werden, nachdem ein Test auf einem kleinen bereits verlegten Bereich erfolgt ist. Im Allgemeinen muss jedes nicht neutrale Reinigungsmittel zuerst auf einer nicht verlegten Fliese oder in einem verdeckten bereits verlegten Bereich getestet werden.

UNI EN Regulations

LE NORME UNI



[Italiano]

[English]



Le norme UNI EN, recepite dal CEN, (Commission Européenne de Normalisation), hanno valore in tutta Europa e interessano tutti i tipi di piastrelle, pressate e trafilate, smaltate e non smaltate, di qualunque formato, di sola 1° scelta. Le norme UNI EN trovano corrispondenza con alcune modifiche delle nuove norme internazionali ISO e si compongono di :

NORME GENERALI

La nuova norma armonizzata EN 14411 fornisce definizioni, classificazione, caratteristiche e marcatura per le piastrelle di ceramica ed annulla e sostituisce la norma EN 87.

La nuova normativa UNI EN ISO 10545_1 stabilisce le regole per la composizione del lotto di campionamento e sostituisce la precedente norma EN 163.

NORME DI PRODOTTO

Le piastrelle di ceramica sono suddivise in gruppi secondo il metodo di formatura ed il grado di assorbimento d'acqua. Sono contraddistinti due gruppi A e B, in funzione del metodo di formatura:

A Piastrelle estruse (ovvero formate tramite il passaggio della materia allo stato plastico, attraverso un "trafilatore" che costituisce un nastro in seguito tagliato alla misura voluta).

B Piastrelle pressate (ovvero ottenute tramite la pressione della materia prima allo stato di polvere secca, in appositi stampi). Tali piastrelle possono essere smaltate successivamente, o non smaltate.

I gruppi sono a loro volta suddivisi in sottogruppi, secondo il grado di assorbimento d'acqua (porosità) presentato:

- Gruppo B Ia = $E \leq 0,5\%$ UNI EN 14411_G
- Gruppo B Ib = $0,5\% < E \leq 3\%$ UNI EN 14411_H
- Gruppo B IIa = $3\% \leq E \leq 6\%$ UNI EN 14411_J
- Gruppo B IIb = $6\% < E \leq 10\%$ UNI EN 14411_K
- Gruppo B III = $E > 10\%$ UNI EN 14411_L

Le norme definiscono per ogni gruppo di prodotti le dimensioni, le tolleranze dimensionali, le caratteristiche meccaniche, fisiche e chimiche, l'aspetto e la designazione delle piastrelle ceramiche. Le piastrelle dell'attuale gamma sono tutte ottenute per pressatura e appartengono ai gruppi B Ia, B Ib, B IIa, B IIb, B III.

NORME PER I METODI DI PROVA

Queste norme definiscono i metodi per la determinazione delle caratteristiche dimensionali e di aspetto, delle proprietà fisiche e delle proprietà chimiche.

La norma 14411 fa riferimento ai metodi di prova delle nuove norme UNI EN ISO 10545.

The UNI EN standards, adopted by the CEN (European Committee for Standardization) are valid throughout Europe and apply to all types of first choice tiles, pressed and extruded, glazed and unglazed, of any size. The UNI EN standards are compatible with the latest amendments of the new ISO international standards, and include:

GENERAL REGULATIONS

The new harmonised standard EN 14411 that provides definitions, classifications, features and designation requirement for ceramic tiles and annuls and replaces standard EN 87.

The new standard UNI EN ISO 10545_1 that sets forth the rules for the composition of sample lots, and replaces the previous standard EN 163.

PRODUCT REGULATIONS

Ceramic tiles are divided into groups according to how they are formed and their water absorption characteristics. In terms of forming methods, there are two groups: A and B:

A Extruded tiles (formed by means of passing a malleable paste through an extrusion machine; the resulting band is cut into the desired dimensions).

B Pressed tiles (obtained by pressing powdered raw materials in special molds). Afterwards, these tiles may be glazed or not.

The groups are broken down further according to their water absorption characteristic (porosity):

- Gruppo B Ia = $E \leq 0,5\%$ UNI EN 14411_G
- Gruppo B Ib = $0,5\% < E \leq 3\%$ UNI EN 14411_H
- Gruppo B IIa = $3\% \leq E \leq 6\%$ UNI EN 14411_J
- Gruppo B IIb = $6\% < E \leq 10\%$ UNI EN 14411_K
- Gruppo B III = $E > 10\%$ UNI EN 14411_L

The regulations define the sizes, the size tolerances, the mechanical, physical and chemical properties, the appearance and designation of the ceramic tiles in each group. The present range of tiles is entirely composed of pressed tiles and belongs to groups B Ia, B Ib, B IIa, B IIb, B III.

REGULATIONS FOR TESTING METHODS

These regulations define the methods to be used for determining size and appearance characteristics, as well as physical and chemical properties.

Standard 14411 refers to the testing methods of the new UNI EN ISO 10545 standard.

Le norme UNI EN

UNI EN Regulations
Die UNI EN-Normen
Les Normes UNI EN

L'Azienda assolve agli obblighi sulla marcatura CE

The Company fulfils its CE marking obligations through
Die Firma erfüllt die Verpflichtungen für das CE
Conformément aux dispositions en matière de marquage CE

CE Marking

CE Kennzeichen
Marquage CE



Marchio CE



Azienda
Company

MOMA
ceramiche

SISTEMI DI
GESTIONE CERTIFICATI

CQY
CERTIQUALITY

UNI EN ISO **9001:2015**





idea ceramica // by MoMA Ceramiche Group
<https://www.gruppomoma.com/>

A large, industrial warehouse filled with hundreds of pallets stacked high with white ceramic tiles. The perspective is from an elevated position, looking down into the warehouse. The background shows the structure of the building and some outdoor areas.

We are here!
Noi siamo qui!

Finale Emilia (MO) - Via Panaria Bassa 17/A - Italy

Tel. +39 0535 90401 / info@ideaceramica.biz

www.ideaceramica.net

idea
ceramica

Leader Europea di produzione rivestimenti ceramici in bicottura

Rivestimento Wall tiles

European leader in the production of double-fired ceramic wall-tiles

MOMA
ceramiche

Azienda Company

Finale Emila (MO) - Via Panaria Bassa 17/A - Italy

Tel. +39 0535 90401 / info@ideaceramica.biz



Bicottura

Ecologica / Ecological

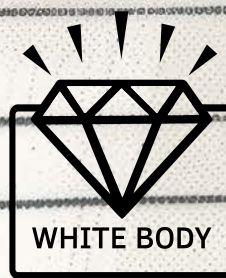

Pasta Bianca White Body

Ambiente / Environment



Riciclo Totale

100% Full recycling



0

Km zero

100%

Materie prime locali
Local raw materials

The background is a complex composition of textures and colors. At the top left, there is a brown area with a pebbled, leather-like texture. To its right is a dark blue area with a fine, grainy texture. The central portion of the image is dominated by a light beige or cream color with a prominent, irregular, stone-like or mosaic texture. In the bottom left, there is a dark blue area with a fine, grainy texture, partially overlapping a semi-circular shape. In the bottom right, there is a light beige area with a fine, grainy texture, also partially overlapping a semi-circular shape. The overall composition is abstract and layered.

PRICE

YOUR

HOME